The ICS Project

Interacting Cognitive Subsystems

Modelling multimodal interaction:
A theory-based technique
for design analysis and support

An INTERACT'97 tutorial presented by

Jon May

This tutorial material has been developed by
Jon May, Sophie Scott and Phil Barnard
March 1997

This material has been developed by
MRC Applied Psychology Unit, Cambridge, UK
Department of Psychology, University of Sheffield, UK
Department of Psychology, University of Copenhagen, Denmark.

Timetable

This half-day tutorial is divided into three sessions, each of which will last about an hour.

Session 1: The cognitive framework

This session will introduce the Interacting Cognitive Subsystems (ICS) framework, and show how the notion of levels of mental representation and information flow can be used to understand a range of everyday tasks.

The ideas of information structure and transformation will be introduced, and multimodal phenomena used to illustrate the different routes that information can take through the overall architecture, and the different consequences that this can have for perception.

Session 2: Application to HCI

The cognitive framework introduced in session one will be applied to a range of HCI scenarios.

The aim here is to show how an understanding of the cognitive resources required to use an interface can help the designer to anticipate usability problems and, more importantly, can help them identify design resolutions.

Session 3: Tools and Techniques

The handbook will be introduced, and the notational techniques developed for the analysis of representational structure will be described. These will be illustrated through visual structures, task structures and acoustic structures.

Abstract

This Guide is intended to help people who design computer interfaces to use psychological principles to construct the appearance of computer interface objects, their arrangement on the display, their behaviour, and their relationship to the users' tasks.

There are many books that provide 'guidelines' for designing interfaces – some tell you how and when to use different colours and typefaces, how to format columns and tables, and how to make your designs aesthetically appealing. This is not one of those books.

Although they provide a valuable service, and sometimes also try to explain why they are providing the advice that they do, guidelines are intended to be prescriptive – telling you what you should do for each part of an interface. You can follow all of the advice that they provide for every individual part of your interface, and still find that you produce a design that is not 'easy to use'. Books of guidelines cannot tell you how to decide for yourself whether an interface will be usable, nor how to identify the problematic parts of the design so that you can improve them. That is what this Guide tries to do.

It will introduce you to some psychological ideas about perception and cognition – the processes by which people see objects in the world, recognise them, search between them, and use them to reach their goals. The techniques this Guide teaches you will let you decide how difficult it will be for people to group objects together, to tell objects apart, to search for objects, and to switch their attention from one part of the display to another. You don't need to be a psychologist to read this Guide, but when you have read it, you should be able to use these ideas to analyse your interface designs.

Organisation of the Guide

The Guide is organised into several sections. Each section introduces you to some ideas about cognition, with some examples, and shows you how these ideas can be seen to affect the usability of interface designs. The key points in each section are highlighted like this:



this is a key point,
and a **key term** is shown like this.

These key points are summarised at the end of the Guide, so you can use these as an index to refer to particular issues. At several points in the Guide there are exercises for you to try, to check that you understand how the ideas can be used in practice.

The sections build on each other, introducing the simpler ideas first and the more complicated ideas later, and so this isn't a book that you can 'dip into', like a collection of guidelines might be. You have to read it through section by section – but when you have done that, we hope that you'll have learnt enough to put your new skills into practice, without needing to keep the Guide by your side.

Presenter Biography



Jon May

Jon May graduated in psychology from Exeter University in 1983, from where he also obtained his PhD on 'The Cognitive Analysis of Flexible Thinking' in 1987. After working with Prof. Andrew Mathews on attentional biases in clinical anxiety at St. George's Hospital Medical School, London, he moved to Germany in 1989 to work as a full time researcher in Human-Computer Interaction with Alcatel, a multinational telecommunications company. He was employed on a number of EU funded projects, including the RACE project Guidance (as Deputy project manager) and the Esprit project Amodeus (as site manager). In 1992 he returned to the UK, to work with Phil Barnard at the MRC Applied Psychology Unit in Cambridge (as manager of the User Modelling research package within the Esprit project Amodeus-2).

In 1995 he was appointed Lecturer in the Department of Psychology at the University of Sheffield, where he teaches Research Methods & Statistics, Thinking, Reasoning & Problem Solving, and Philosophical Issues in Psychology. His recent research has focused on ways of introducing psychological theory into the design process, to produce more usable computing and telecommunication technologies, and to use the complex tasks typical within the HCI domain to advance psychological theory. A particular theme has been the development of cognitive models that can be expressed formally, facilitating the combined use of psychologically valid models of the user and formal system models.

<http://www.shef.ac.uk/psychology/may/>

<http://www.shef.ac.uk/~pc1jm/>

Contents

•1• Techniques for analysing structure	
Perception is active.....	7
The structure of visual scenes.....	8
Psychological subjects and transitions.....	9
Using diagrams to analyse a display.....	10
•2• A framework for cognition	
Levels of mental representation.....	12
Propositional representations.....	12
The complete cognitive system.....	15
Nine subsystems.....	16
Interacting Cognitive Subsystems.....	18
•3• How objects form groups	
Objects and groups.....	19
Psychological Subjects pop-out.....	20
Pop-out of groups.....	22
•4• Searching through structures	
Pragmatic Subjects and Icon search.....	24
An object's structure affects grouping.....	27
•5• The role of knowledge	
Knowledge can affect structure.....	29
Learning the meaning of objects.....	30
Competing groupings.....	32
•6• The user's task	
Tasks have structure too.....	35
Ambiguity in task structures.....	36
Conceptual structures.....	39
Complex multiwindow displays.....	40
•7• Multimedia Perception	
Relationships between levels.....	44
Blending sight and sound.....	46
Propositional Blending.....	47
Implicational Blending.....	50
Consequences of blending.....	51
•8• Applying the techniques	
Icons for multivariate information.....	52
Dynamic changes in structure.....	53
Summary.....	56
Hints for structuring displays.....	56
Sources of examples.....	71
Index of Exercises.....	72
Acknowledgments.....	72
Index of key points.....	73

•1• Techniques for analysing structure

Perception is active

Our visual environment is made up of objects rather than features. When we look around a room we see different objects, for instance, some books on a desk. It is hard for us to ‘see’ the pile of books as an area of different hues and shades, although that is what is represented by the pattern of light that is arriving at our eyes. The process of perception is one of structuring the sensory information that we receive from objects in the environment so that we can interact with them. We need to be able to see a set of differently coloured planes and surfaces as belonging to a single object, a book, that is distinct from the other planes and surfaces that represent the desk and the other books. If we pick up a book, we expect all of the parts of the sensory world that ‘belong’ to it to move together in a predictable way, and for all of the parts that belong to the ‘desk’ to stay where they are. If we try to pick up a stack of books, we know that the individual books might not remain as a stack, and that the stack cannot be treated in the same way as the individual books that it is made of.

These details about the structure of objects and their inter-relationships are not explicitly contained in the visual information. It must be interpreted, by combining the visual information with knowledge about the world, which we have learnt through our lifelong experience of interacting with it. This is why we can say that perception is active process, blending knowledge and sensation. The structure of the perceived world affects our interactions with it, and our interactions with the world affect our subsequent interpretations of its structure.

Computer displays are just like the rest of the world in this respect. Figures 1.1 and 1.2 show two groups of icons - one of these is a group of different icons, the other a collection of very similar icons. In Figure 1.1, if the user knows what a particular icon in the first array looks like, the dissimilarity will make it easier to locate - it may even seem to ‘pop-out’ from the array. But if they do not know what an icon looks like, and have to read all of the names, they may find it difficult to ‘separate’ the text labels from the ‘background’ of icons.

In Figure 1.2 the icons are all very similar, and so even if the user knows what the icon of the document they are searching for looks like, they may find it harder to locate than in the previous figure. However, the very similarity of the individual icons makes it much easier for the user to ‘group’ them as a single, ordered array, and for them to form a ‘background’ against which the text labels stand out. In this figure, the information provided by the appearance of each icon is less important than the fact that they cluster together to say “we’re all documents”: this becomes an attribute of the group rather than just an attribute of each separate icon.

Designing a computer display is all about choosing the form of objects and arranging them within a two-dimensional area of the screen. As Figures 1.1 and 1.2 show, a correct choice of form and arrangement can affect the way that objects are perceived and dealt with by the user of the computer. Further than this, you need to think about the structure of tasks, and about the relationships between objects on the screen and any sounds that the system makes.

In this Guide we will explain some ideas that can help you to think about the way that people perceive interfaces, and teach you techniques which you can use to analyse designs. We’ll start by looking at

visual scenes, and then introduce some psychological ideas to help you understand the way that people perceive, think and act. This will let us extend the techniques to multimodal interfaces.

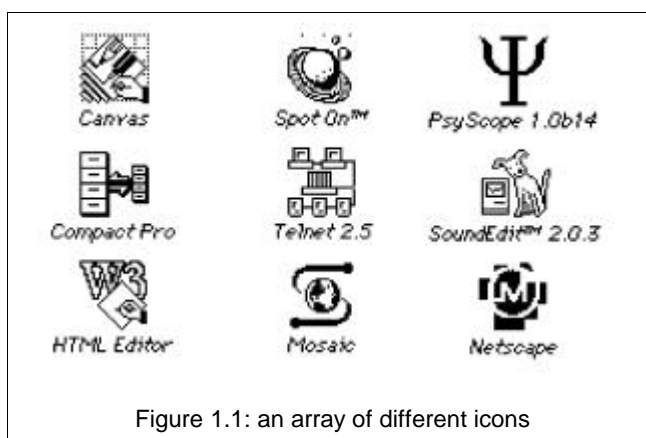

Figure 1.1: an array of different icons

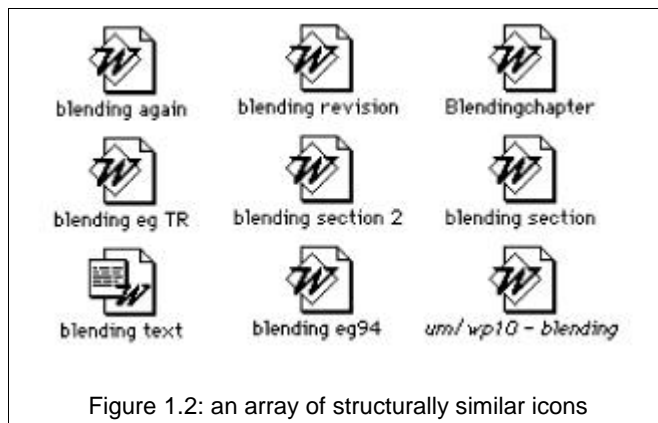

Figure 1.2: an array of structurally similar icons

The structure of visual scenes

Although computer displays are produced on two dimensional, flat screens, we use the same perceptual processes to perceive them as we do to perceive the real, three dimensional world. When we look at a visual scene, whether it is two or three dimensional, the features, colours, and textures in the sensory information that we receive from our eyes group together to form objects. The scene as a whole is a structure of objects. The objects have certain qualities - they stand out from their background and are discrete entities, which can often be named. If we look closely at an object, though, we can see that it also has a structure, and may be composed of other objects. We can perceive the

world at several different scales, from a global level, down through many levels of detail. You could stand at the door of the room in Figure 1.3 and see 'an office - a room with objects in it'. You could then focus your attention towards the far wall, which is a plane surface with items of furniture superimposed on it. Within this level you could see the window, a chair and desk. Within the region of the desk you could see a pad of paper. The pad has a pencil resting on it, and is written upon. You could look at the text on the page by moving down into the structure of the pad, and moving down again you could see the individual words that make up the text (if you were near enough).

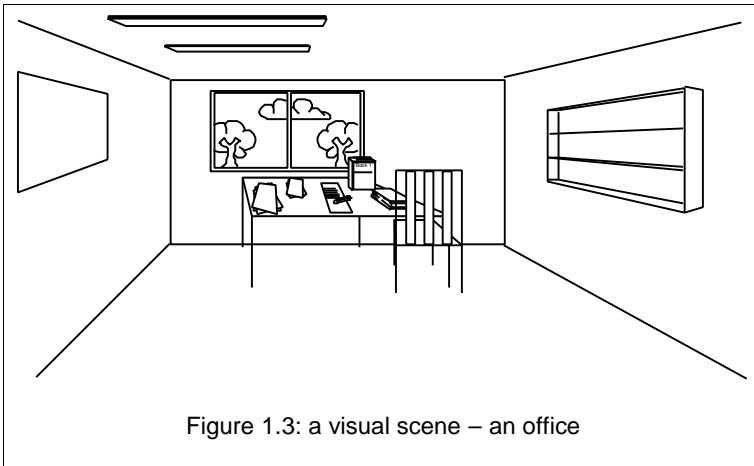

Figure 1.3: a visual scene – an office

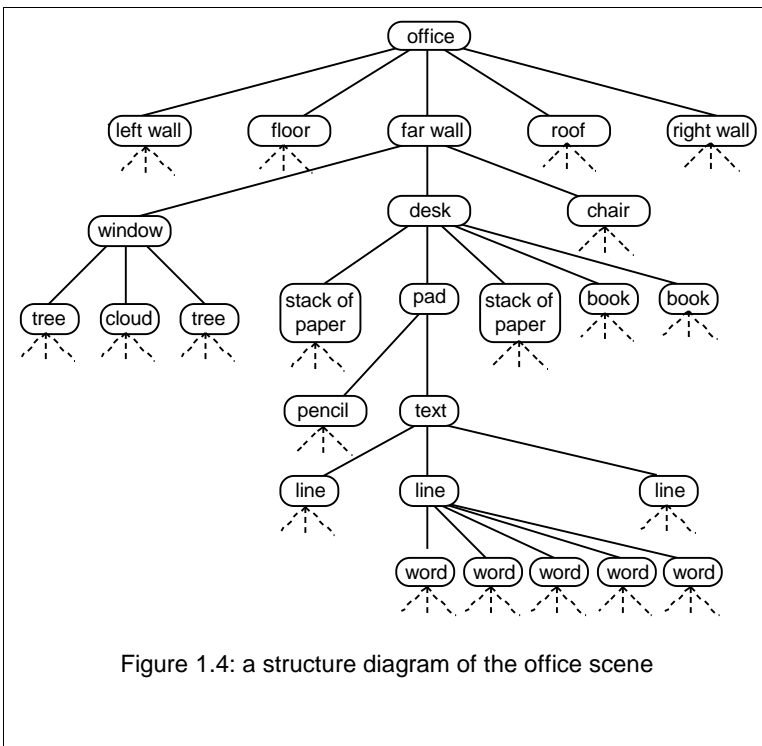

Figure 1.4: a structure diagram of the office scene

This hierarchy can be represented as a structure diagram, as in Figure 1.4, where the different horizontal groups in the figure represent different levels of visual structure. At each of these levels, sensory patterns of light are interpreted as forming a group of individual objects. Each object itself 'contains' visual details that can be further interpreted as another group of objects. The dotted lines indicate that some objects have further structural details that we have not included.

What we actually perceive from moment to moment is limited by the level at which we are analysing the scene. While attending to the pad of paper we can be aware of the relationships it has to the other objects within its own 'group' – the stacks of paper, and the books – and we can be aware of their shared relationship to the desk. We can also be aware that the pad itself has some structural details and, if we wanted to, could attend to some object of this structure; perhaps looking at a line of

text.

The hierarchical structure of the visual scene, as represented in Figure 1.4, constrains the direction of visual search. After having attended to the far wall, the words of text cannot be reached by looking at the structure of the window. We have to successively focus in to the desk, the pad and then the text before we can attend to the words. Likewise, after attending to a line of text, attending to a book requires a movement back up the structure, to an object that is at the same level of visual detail as the book (here, the pad of paper).



The **structure** of the scene constrains the way people can search through it.

These two ideas – the structure of visual scenes, and the transitions of attention between objects – are the tools that we will use to analyse the composition of displays. In general, a well composed display will be constructed so that the user can attend to the appropriate object easily. These tools help us to assess the ease with which a user can move their focus of attention around between objects. In the next section we will describe how they are derived.

Psychological subjects and transitions

To describe the way that we change the focus of attention, it is useful to think of the object that is being attended to as the ‘psychological subject’. In the office example of Figure 1.3, there are several different objects on the desk. We can focus our attention on any of these objects, and we can shift our attention between them. Any one of them can be the psychological subject at different times. Other objects at the same level of decomposition in the visual scene form its context, and can be used to discriminate it from other similar or identical objects. Because these other objects provide information about the subject, they are collectively called its ‘predicate’.



The object that is being attended to is the **psychological subject**. Other objects in the same group form its **predicate**.

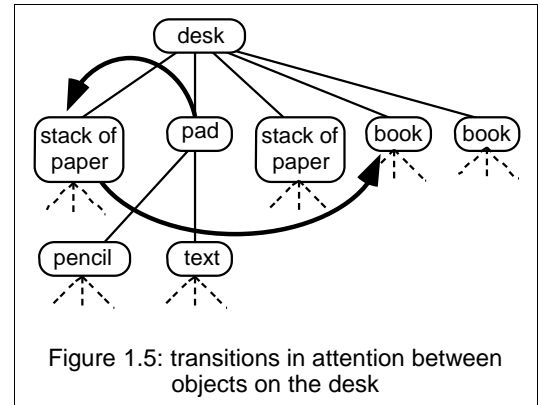

Figure 1.5: transitions in attention between objects on the desk

Figure 1.5 shows part of the office – the group of objects that are on the desk - as attention switches from the pad to a stack of paper, and then to a book, as indicated by arrows. Adding a lot of arrows to the structure diagram would make it rather complicated, especially if attention repeatedly moved back to the same object, and so we need to use a representation that can include time as a dimension.

Figure 1.6 is an example of a ‘transition path diagram’ that describes the transitions in attention made in Figure 1.5. Each row represents a different moment in time, and a new focus of attention. One object is shown on a black background: this is the psychological subject at that moment. In the first row it is the pad, and the other objects form its predicate, and are listed in a group to its right. As successive transitions are made from object to object, each in turn moves left to become the subject, as shown by the second and third rows. The lines between the rows show the visual transitions that are made as attention shifts between the objects.

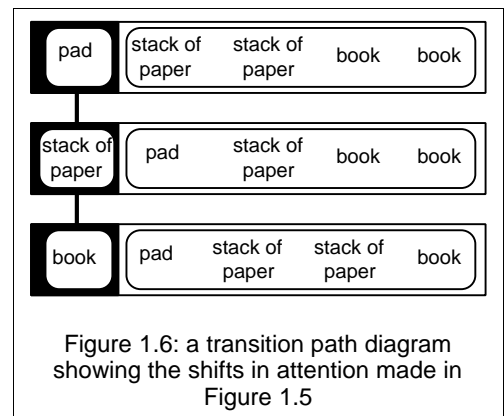

Figure 1.6: a transition path diagram showing the shifts in attention made in Figure 1.5

Figure 1.6 might not seem to offer many advantages over Figure 1.5, but that is because the transitions were quite simple. As well as shifting attention between objects within a group, it is also possible to ‘zoom in’ and ‘zoom out’, attending to an object’s group - the larger object it belongs to - or to a part of its structure - an object that it visually contains, surrounds, or is made up of. We need to be able to represent these possible transitions as well.



Structure diagrams show the hierarchical relationships between objects.

Transition Path diagrams show changes in the psychological subject and predicate in time.

Figure 1.7 shows how these ‘up’ and ‘down’ transitions can also be represented in a transition path diagram. As well as showing the predicate of the psychological subject, each row includes (on the left) the group that the objects belong to, and (on the right) the constituent structure of the psychological subject. This diagram now contains all of the objects that could become the subject following a transition in attention. In the first row the pad of paper is again the subject, but the transition that is made next is ‘up’ the structure, to the desk. The ‘U’ shape linking the first row to the desk indicates that the transition is ‘up’ the structure from many objects (the pad and its predicate) to a single object (the desk).

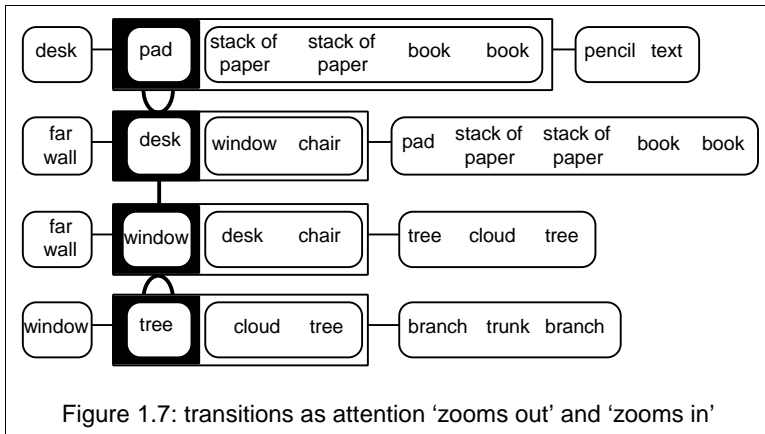

Figure 1.7: transitions as attention 'zooms out' and 'zooms in'

In the second row the desk is shown as the subject. Now the predicate consists of the other objects that are at the same level of decomposition as the desk - the window and the chair - and the 'far wall' is shown as the group that they belong to. The pad, the stacks of paper and the books, that were the active level of the previous representation, are now shown as the desk's constituent structure. They have moved to the right, as has the desk. Each time a transition is made 'up' a structure, the old group moves right to become the new subject, and the old subject-predicate level moves right to become the new

constituent structure. In the third row a 'within level' transition is made to the window, so that it becomes the subject: the group remains the same, but the constituent structure changes, to show which transitions 'down' the structure are now possible from the window. The previous subject has become part of the predicate. A point to notice here is that the objects within the predicate are 'unordered' - they are all equally able to become the subject. The second and third rows are linked by a plain line, to show that the transition is just from one object to another, within the same group. Finally, in the bottom row a transition is made to a tree - one of the objects that the window 'contains' in its structure. The group of objects that was on the right of the third row has moved left to become the 'active level' of the representation in the fourth row. The subject is the tree that is being attended to, the predicate consists of the other objects in the window's structure, and the tree's constituent structure must be included on the right of the row. The window has also moved left, to become the group. Each time a transition is made 'down' a structure, the old subject moves left to become the new group, and its constituent structure moves left to become the new subject-predicate level. The 'inverted-U' linking the third and fourth rows now indicates that the transition has been from a single object, the window, to the many objects in its structure.

Transition path diagrams help to make it clear how simple or how complicated it will be for users to move their attention from object to object within a display. On each row, all of the objects that could be attended to following a transition are indicated. A transition 'up' the structure makes the group and subject-predicate move right in the row. A transition 'down' makes the subject and its constituent structure move left in the row. In Figure 1.7, it took three transitions to look up from the pad, and to look at a tree. It might take a user of a computer several transitions to move their focus of attention from the document they are reading on-screen to locate an icon in a menubar, depending on the structure and grouping of all of the objects. In analysing a display, it is helpful to construct a structure diagram first, and then to use it to draw transition path diagrams for particular tasks that a user will want to carry out. The next section shows how this can be done for a typical computer display.

Using diagrams to analyse a display

The 'office' example was a real-world, three dimensional structure, but the structural and transition path diagrams can be used to analyse two dimensional computer displays. The only differences between the two 'control panels' in Figure 1.8 are the boxes that have been drawn around the groups of words and buttons. This might be an aspect of the design that is left to a designer's aesthetic judgement, or it might be constrained by the interface software 'toolbox'.

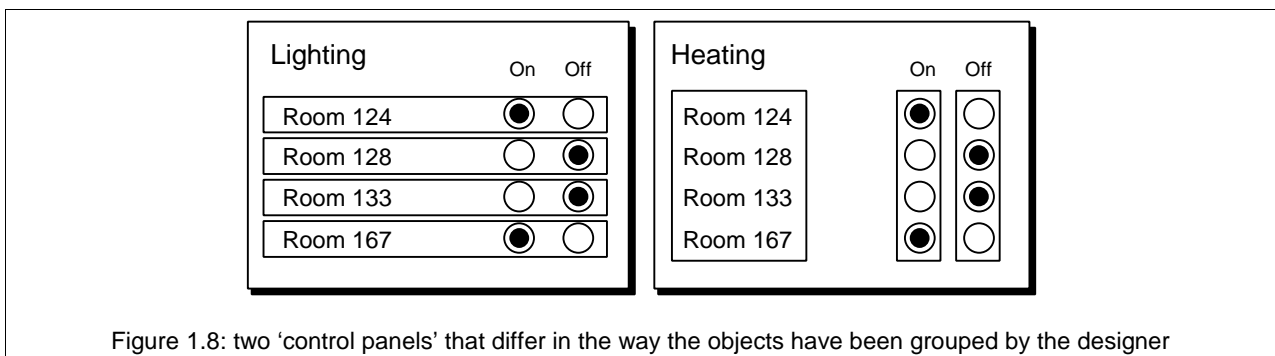

Figure 1.8: two 'control panels' that differ in the way the objects have been grouped by the designer

The 'lighting panel' has boxes that relate objects together functionally, so each room label is linked to its own on and off buttons. In the 'heating panel', the objects have been linked by type, so that all of the room labels, on buttons and off buttons each form different groups. This is a fairly small difference, and if anything, the heating panel looks more aesthetically appealing. The structure diagrams for the two panels (Figure 1.9) show the difference that these boxes make to the grouping of the objects. The lighting panel is made up of four 'groups', one for each room, each containing a room label and an empty and filled button. The heating panel consists of three groups, one of four similar room labels, and two groups of mixed circles.

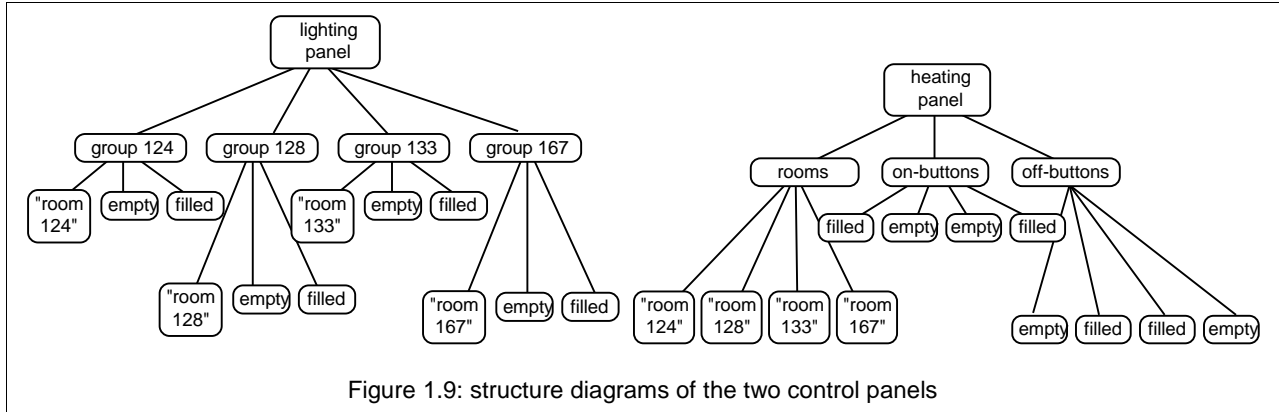

Figure 1.9: structure diagrams of the two control panels

If we draw transition path diagrams for a user who has to turn the lights and heat on in Room 133, we can see the difference that these groupings have made to the panels' 'ease of use'. For the lighting panel, the task is quite simple, as the diagram in Figure 1.10 shows. The button that turns the lights on is part of the predicate of the label for 'room 133' and so only one transition is necessary. The transition is made within a single group, and so the object to the left of the subject does not change. The empty circle has no constituent structure, and so when it is the subject nothing is shown to the right of the row, to indicate that no further transitions could be made 'down' the structure.

The situation is quite different for the 'heating panel'. Now the room label and the button are in different groups, and the user has to momentarily move their attention up the structure to the 'rooms' group, across to the on-buttons, and then down again to the third button (Figure 1.11). Here three transitions are needed instead of one, and so for this particular task, we can say that the 'lighting panel' will be easier to use than the 'heating panel'.

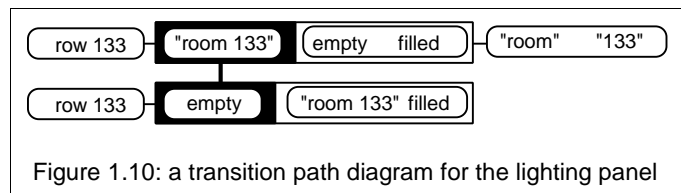

Figure 1.10: a transition path diagram for the lighting panel

The idea of 'task' is very important, of course. If instead of a task that required the use of the room label and a button, the user had to operate on each of the on-buttons in sequence, regardless of the room labels, the 'heating panel' might be found to have an advantage.

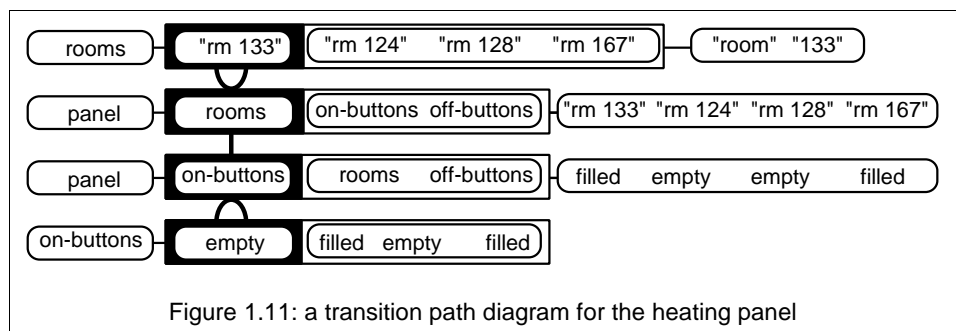

Figure 1.11: a transition path diagram for the heating panel

Suppose the user just had to make sure that all the heaters were on. Once the user had located the group of on-buttons, and attended to one of the buttons, the other buttons would all be part of the predicate. This task would require fewer transitions than the equivalent task of turning on all of the lights.

This example shows that it is vital to make the grouping of screen objects correspond to the task that the user is going to perform, because this determines the way that they will have to move their attention between the objects. In choosing between different possible forms for objects and different ways of arranging them, the designer is attempting not just to make an aesthetically pleasing interface, but one which helps the user perform a particular task.

•2• A framework for cognition

Levels of mental representation

In the previous section we have seen that sensory, visual information about the world needs to be interpreted as an object based structure for us to make any sense of it. Both visual and object structures are mental representations, but at different levels of information. The visual level is derived from the raw sensory data obtained from the eyes, whereas the object level is derived from the combination of the visual representation and the perceiver's knowledge and experience of the world. This means that there must be a set of mental processes that convert the visual representation into an object representation, and that there must be other processes that allow memory to influence the object representation.

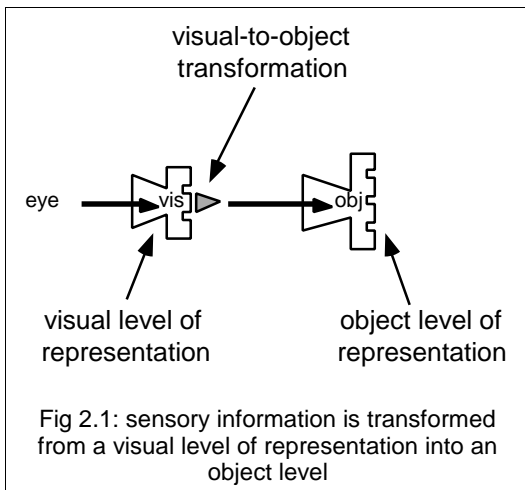

The shapes in Figure 2.1 look odd, because they are parts of a larger model of human cognition, which we are going to describe piece by piece. When all of the parts are in place, their shapes will become more meaningful. The part of the overall model shown in this figure illustrates the process of perception that we have described so far. Sensory information about the world is detected by the eyes, and turned into a visual representation that contains a wealth of detail about colours, shades, contrasts, angles and edges. A mental process then 'interprets' this information, transforming it into an object representation, which contains information about lines, shapes, depth, position and orientation.



Sensory information from the eyes forms a **visual representation**.



Perceptual information is contained in an **object representation**.

It is important to remember this distinction between the sensory level of information in the visual representation, and the perceptual level of information in the object representation. One advantage of making this distinction is that it helps us analyse what people will *subjectively* think about a display design (their object representation) as well as what is *objectively* presented to them on the computer screen (their visual representation). The transformation from a visual to an object representation involves the structuring of sensory data into objects, and the grouping together of those objects.

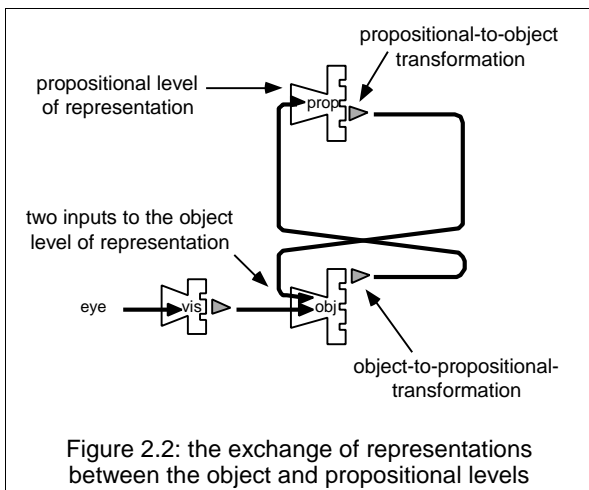

The visual-to-object transformation is affected by the clarity of the visual representation, so that detailed, high-resolution displays will be easier to convert into object representations than jagged, low resolution displays. It also develops with experience, so that familiar visual patterns can be converted into object structures more accurately than novel patterns - essentially, the more often a representation has been transformed in the past, the easier it becomes to transform in the future. This is one way that experience can affect perception. Another way is shown in Figure 2.2.



The **visual-to-object** transformation process structures and groups the visual scene

Propositional representations

Just as the visual-to-object transformation interprets the visual representation to produce a more abstract, but more structured object representation, the object representation can be interpreted to produce an even more abstract and structured 'propositional' level of representation. This new level contains factual, everyday knowledge about the objects - their names and properties, and the way that they can be expected to relate to each other and to interact. In the same way

that the visual-to-object transformation added structural information that wasn't necessarily present in the sensory data, so the object-to-propositional transformation adds a meaningful identification of objects that isn't necessarily present in the object representation.

For example, a pattern of light and shade can be interpreted by the visual-to-object transformation as a set of flat, square surfaces belonging to two separate but overlapping objects, and the object-to-propositional transformation can then interpret this as a book placed on top of a notepad. It too develops with experience, so that familiar objects in their normal positions are more easily recognised than unfamiliar objects, and than objects in strange orientations. The end result of this sequence of mental processing is that we are able to recognise and identify objects, and to access knowledge about the way they behave and what they do.



The **object-to-propositional** transformation process identifies and relates objects

The remaining part of Figure 2.2 is perhaps the most important. It shows a third transformation process taking place, this time a propositional-to-object transformation. Although all transformations develop with experience, and so allow a slow form of learning to take place, the addition of this third transformation provides a more immediate way for knowledge and expectations about the world to influence perception. It takes the propositional representation, and interprets it to feed a new object representation back to be combined with the visually derived object representation. The object representation that results is therefore really a blend of external data obtained by the senses from the world, and internal data constructed from a mental, propositional representation of the world.



The **propositional-to-object** transformation process feeds back information about object structure

The 'active nature of perception' that we began this guide with is becoming much more active: with the addition of this feedback loop, it becomes possible for the object representation that a viewer forms at one moment to influence the object representation that is formed the next moment. The object representation is receiving information from both the visual-to-object transformation and the propositional-to-object transformation.



The object representation that is perceived is a **blend** of information from visual and propositional sources.

The representation that the object-to-propositional transformation actually uses is a result of these two inputs being blended together: the parts that match reinforce each other, and parts that don't match are discarded. This can be of great benefit in perception, where the sensory, visual level of representation is often incomplete or distorted. When the visual-to-object transformation is unable to produce a clear object representation, the contribution of propositional knowledge allows the viewer's expectations and knowledge about the world to clarify matters. We'll go into more detail about different sorts of blending in Section 7, but for now we will concentrate on its effects at the object level.

The object in Figure 2.3 has the identity 'teddy bear' for a viewer who has already learnt the propositional representation of such an item, and knows that teddy bears generally have a head with ears that stick out, and limbs that are spread out. As soon as the object-to-propositional transformation produces an identification of the shape as a teddy-bear, however weak, the viewer's propositional knowledge of teddy-bears can be brought into play. The propositional-to-object transformation can produce details about what teddy-bears ought to look like. Where these match the visually derived data, the shape can be interpreted as fitting the propositional identification. Slight differences between the propositionally derived representations and the visually derived representations cancel each other out, and do not form part of the object representation. The gaps in the outline, for example, become unimportant. The object-to-propositional transformation now has an even more bear-like representation to work with, and so the feedback between object and propositional levels of representation becomes progressively stronger.

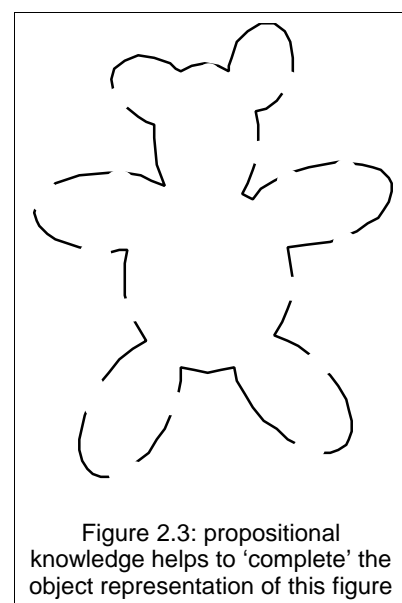

Figure 2.3: propositional knowledge helps to 'complete' the object representation of this figure



Propositional representations can fill in gaps in object representations derived from incomplete visual representations.

Even if the viewer of this Figure has no idea of what they are about to see, the extreme familiarity of this outline enables the feedback between the object and

propositional representations to settle on this interpretation very rapidly, perhaps ignoring any visual features that did not quite ‘fit’. People have a strong tendency to give objects nameable identities if they possibly can, reflecting the extraction of propositional knowledge. These names then affect the way the objects are perceived. The propositional influence on the perception of familiar forms like this is very resistant to distortions in the shape, provided that key invariants between the objects are met. If Figure 2.3 is looked at upside-down, for example, a different teddy bear can be perceived (or perhaps the longer ‘ears’ now make it look like a rabbit).

For someone who has never seen a teddy bear, and who has no other propositional representation that ‘leaps in’ to influence the perception of a single object, the form may appear to be a number of overlapping circles and ovals, but the absence of arcs in the centre of the form completing or even continuing these circles means that it is much more likely to be seen as a single, irregular shape.

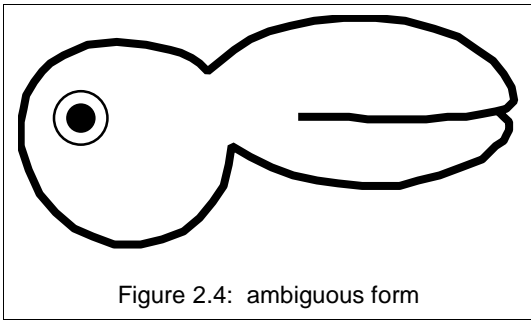

Figure 2.4: ambiguous form

The feedback loop between the propositional and object levels of representation tries to settle on one consistent interpretation of a figure. The form in Figure 2.4 can be seen as either a rabbit (looking to the left) or a bird (looking to the right), but it cannot be seen as both at the same time: the perception must ‘reverse’ between the two interpretations. Notice that the propositional identity given to the Figure constrains the structure of the object representation – the beak becomes a pair of ears, and the direction that the eye is looking changes. These structural changes in an object representation that has been derived from a single visual representation are indicative of propositional knowledge being brought to bear.



Propositional representations help the object representation settle on one interpretation of ambiguous figures

Once an object has been propositionally identified, we are able to ‘go beyond’ the available sensory data to use our knowledge about the world to enhance its object representation. If we are told that an object is ‘round’, or has a ‘hole’, then we can combine the sensory information that is available now with information that we have experienced in the past as being common to ‘round’ or ‘holed’ objects (Figure 2.5). If we were told that it was ‘round’, we might actually interpret it as ‘spherical’, even if the appropriate sensory information (such as shading) is not immediately available. If we were told that it was a ‘hole’, we might be able to perceive some visual features as belonging to another object that is visible through it.

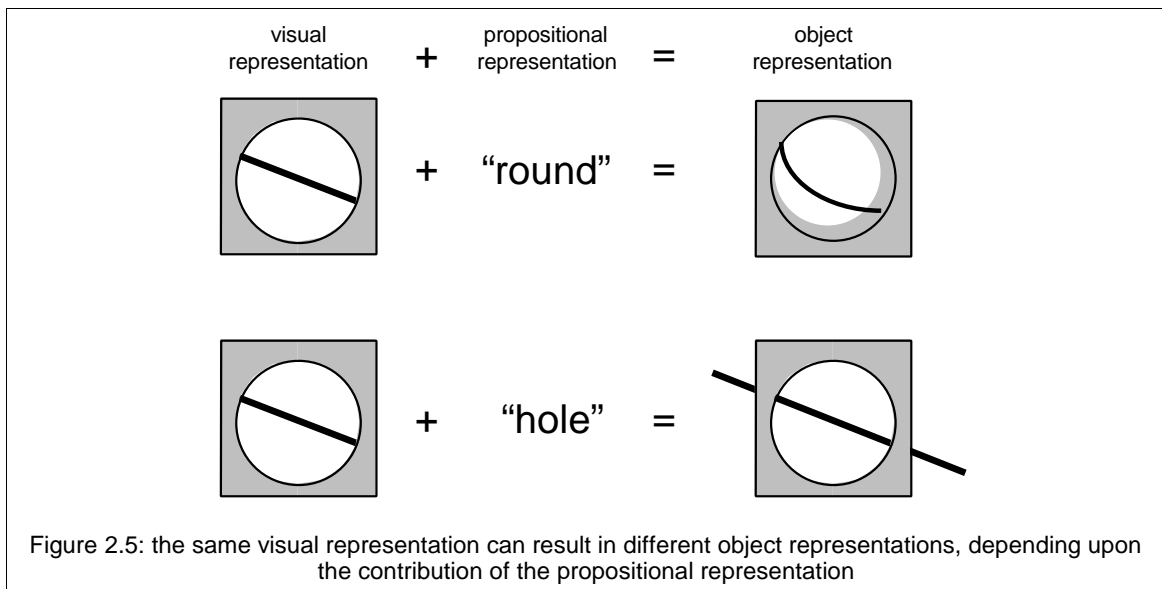

The perception of ambiguous figures depends on what the viewer knows, and what they expect to see.

If it were not for the contribution of propositionally derived knowledge about objects, we would be unable to use simple verbal labels like ‘book’ or ‘desk’ in the structure diagrams of Section 1. We’d have to use descriptions like ‘flattened

cuboid with one side convex along one axis and the opposite side concave and slightly ridged’, or ‘flat horizontal rectangle with four thin vertical blocks attached underneath at each corner’.

These long-winded descriptions are more like the actual products of the visual-to-object transformation, which can identify shapes and group them together structurally, but cannot identify what they are. Of course, the structure diagrams and transition path diagrams would be impractical to draw if we tried to use such detailed descriptions, and so we use the propositionally-based labels instead, but the examples we presented earlier all contained object representations.

The psychological subjects and the parts of the predicate were all objects, and the point of constructing them was to identify how people would be able to move their focus of attention between objects in the world, whether they were real objects, or representations of objects presented on a computer screen.

The complete cognitive system

The three levels of mental representation that we have described so far are sufficient to deal with the perception of visual objects, but they cannot deal with other important aspects, such as the perception of sound, or the use of language, nor the individual’s physical actions. To account for these aspects we will have to add more levels of representation, and more processes.

The complete cognitive system is shown in Figure 2.6, which contains the visual and object levels at the bottom, and the propositional level in the middle. The different levels of representation are now linked together in a ‘network’ to show that they can exchange information with each other.

At the top of the figure are two levels that resemble the visual and object levels, but which deal with acoustic information (‘ac’) and ‘morphonolexical’ information (‘mpl’) respectively. The acoustic level does the same for sensory information from the ears that the visual level does for sensory information from the eyes, and just as the object level is a more abstract, structured representation of visual information, so the ‘morphonolexical’ level is a more abstract, structured representation of sound. Its name reflects the fact that it contains information about all sorts of sounds, particularly our human speciality, language. It is also crucial in the perception of other structured noises, such as the tones and rhythm of music, as well as the beeps made by computers.

The acoustic and visual levels both encode sensory information, or the ‘input’ to our minds. On the right of the figure are two levels that encode our mind’s ‘output’, the ‘articulatory’ and ‘limb’ levels (‘art’ and ‘lim’). Both these levels represent physical, motor actions that we intend to produce. The articulatory level specialises in controlling the detailed motion of the mouth, lips and tongue required for us to produce sound output such as speech, while the limb level controls other physical actions, such as hand and eye movements.

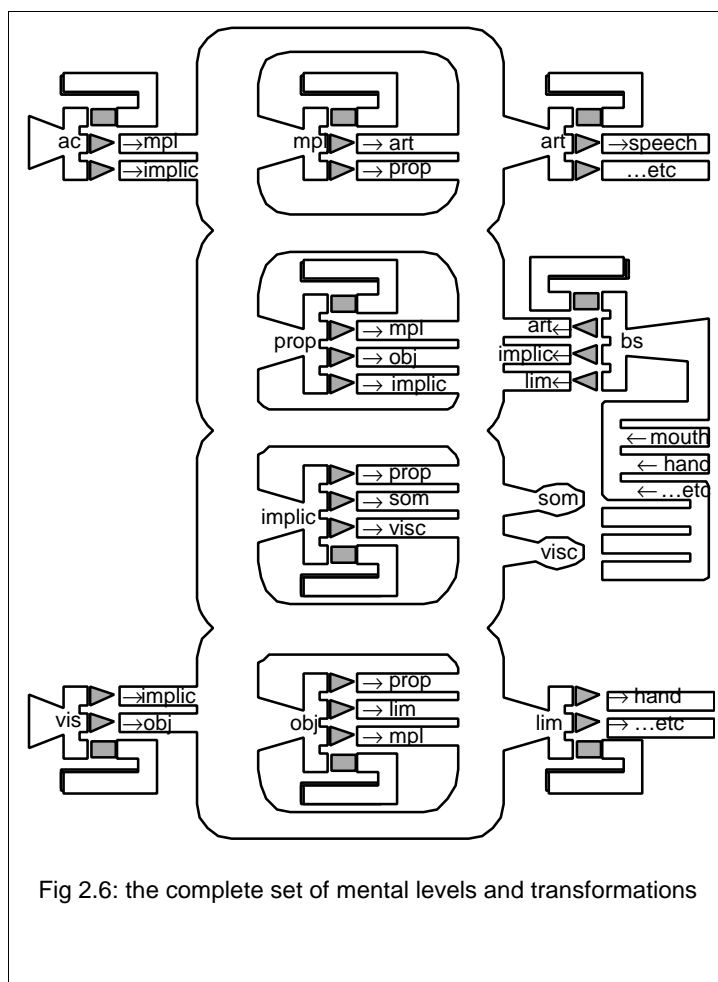

Fig 2.6: the complete set of mental levels and transformations

As their positions in the diagram show, the representations at these levels are mainly produced by transformations of the morphonolexical and object levels, but they also receive information from the ‘body state’ level (‘bs’), which is a third source of sensory information. This information represents all of the touch, smell and taste sensations that our body detects, as well as information from internal sensations such as the position of our arms and legs, and the state of our muscles.

The transformations of this level of representation are important in providing ‘feedback’ to regulate and co-ordinate our physical actions, because the limb and articulatory levels are representations of intended actions that have been mainly produced from the morphonolexical and object levels, but which have been blended with information from the body state level. If you’ve ever had a tooth filled, for example, you’ll know how difficult it is to rinse your mouth out while the anaesthetic is preventing you using the body state information to detect the position of your lips - even if you are grateful for the absence of pain from your tooth.

The three sensory levels of representation, and the propositional level, can all be used to produce the final level of representation we need, the ‘implicational’ level (‘implic’). This is the most abstract level of all, and it represents the general meaning of information. So if you see something red, the visual-to-implicational transformation produces a representation of all the things that you have learnt red to mean – not just the fact that the object is red. If you are simultaneously hearing a continuous bell ringing, the acoustic-to-implicational transformation will be producing a representation of the general meaning of the sound of bells – not just the fact that you are hearing a bell. The ‘facts’ are propositional; their meaning is implicational.

When the outputs of these transformations are blended together to form a single implicational representation, all of the common elements combine, in the same way that the object representations derived from visual and propositional representations could be combined. In the example of ‘redness’ and ‘bells’, you would hopefully form the implicational representation of ‘dangerousness’. The implicational-to-propositional transformation could then turn this into a direct, propositional fact that there is something dangerous around.

Figure 2.6 also shows transformation processes that turn the implicational representations into physical effects within our body, and so can affect our moods (‘som’ means somatic, and ‘visc’ means visceral). The way we interpret the world can interact with the way we feel, which can in turn affect the way that we interpret the world. When you are feeling tired and stressed, working to complete a piece of work before a deadline, your computer’s ‘beep’ can seem very much more annoying than when you are feeling fresh and alert.

Nine subsystems

Figure 2.6 includes many more transformations than we have described so far – all of the shaded triangles indicate a possible transformation from one level of mental representation to another. To keep the diagram simple, we have not included all of the arrows that link the different levels together. The object level of representation, for example, can be used for three different transformations. As well as the object-to-propositional transformation that we have already described, there is the object-to-limb transformation that controls motor actions, and an object-to-morphonolexical transformation, which develops as we learn to read fluently, and enables us to ‘hear’ words in our mind as we look at text.

For convenience we can think of all of the transformations that can be made from a given level of representation as part of the same cognitive subsystem, there being one subsystem corresponding to each level of mental representation. Each of these subsystems receives the representations it is specialised for, possibly from a variety of sources, and can produce a variety of representations for other subsystems to receive.

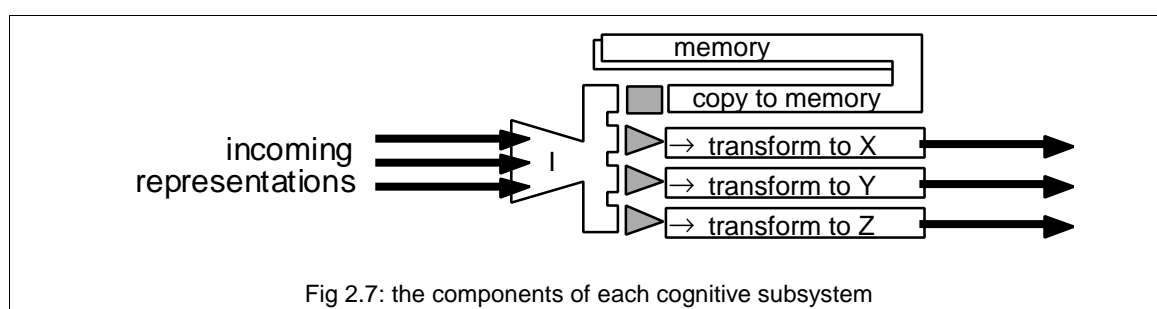
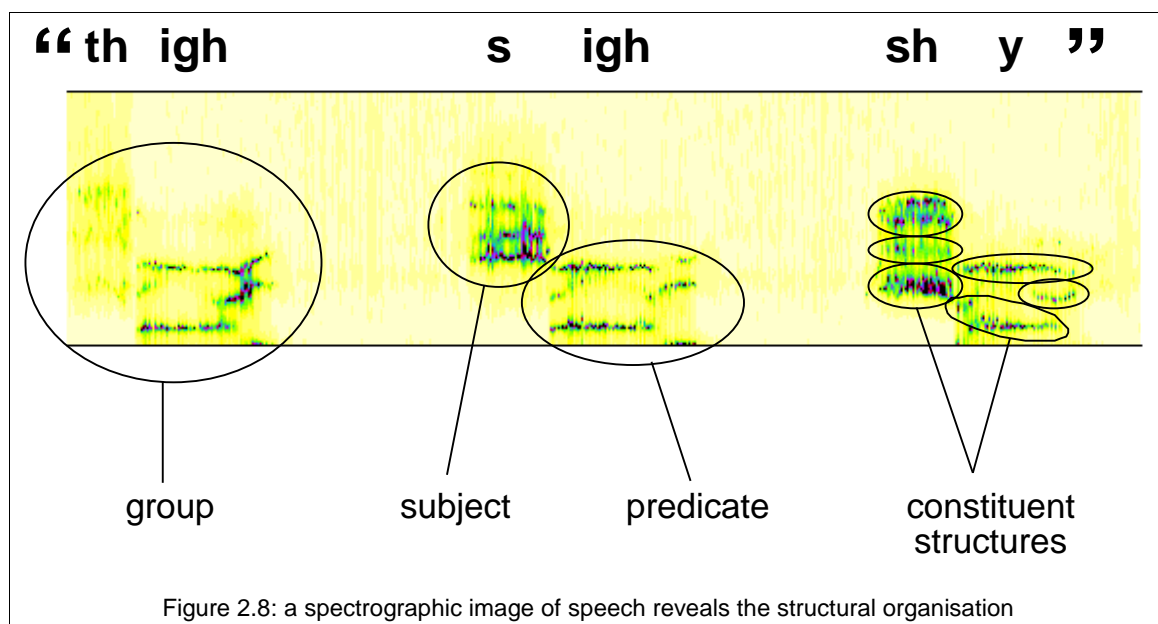

Fig 2.7: the components of each cognitive subsystem

A schematic picture of a typical subsystem is shown in Figure 2.7. It receives representations from the left, and each of the shaded triangles indicates a different transformation process, with the transformed representations passing out to the right. The shaded rectangle indicates an additional process, but instead of transforming the incoming representations, this process copies them, unaltered, into memory.



Each level of mental representation is processed by a different **cognitive subsystem**.

As you can see from Figure 2.6, each of the nine individual subsystems has such a copy process, and each has its own memory. These memories allow each subsystem to learn about the representations that they receive, so that if a representation ‘looks like’ something that has been received before, it can revive a representation in memory. The revived representation can then be used by one of the transformation processes instead of the incoming representation.



All nine subsystems have a **common architecture**, including their own memory.

So if your object subsystem receives a representation of ‘ball’ from the propositional subsystem, you can produce a mental image of all sorts of balls from memory, without having to use any visual representations at all. Similarly, the propositional subsystem can produce a morphonolexical representation of the word ‘ball’, and you can imagine the word ball being spoken in many different voices - but normally, you would hear it in your own voice, since that is the voice that you hear most often, and so your morphonolexical memory is mainly filled with it.

This example makes the point that the same propositional representation, the concept of a ball, can be used to revive quite different sets of memories, depending upon the level of representation that it is transformed into, and which subsystem’s memory is subsequently accessed. Since the subsystems process different levels of representation, their memories contain different types of information.



The **content** of a memory depends upon the subsystem in which it is stored.

While each of the levels of representation contains a different sort of information, all representations are structured in the same general way as the object representations, and can all be thought of as having a group, subject-predicate and constituent structure. The spectrographic image of the energy at different frequencies within a fragment of speech shown in Figure 2.8 reveals this structure in an acoustic representation. The generic structure of information, regardless of the level of representation, is one of the consequences of the common architecture of the subsystems. It means that the same techniques of structural analysis, using structure diagrams and transition path diagrams, can be used to understand cognition whatever the level of representation.



All levels of representation can be described as having groups, subject-predicate and constituent structures. Structure diagrams and Transition Path diagrams can be used for all levels of representation.

Interacting Cognitive Subsystems

Each of the nine subsystems is continually receiving representations, copying them into its own memory, and transforming them into other representations, and they all act in parallel with each other. The nature of the information that each subsystem processes is summarised in Figure 2.9. As the examples we have used in this section have emphasised, it is the combination of representations from different sources, and the exchange of representations between levels of representation, that provides human cognition with its elaborate and complex richness.

The framework of cognition that we have described is called ‘Interacting Cognitive Subsystems’, or ICS, since it is the interaction between the subsystems, rather than their individual action, that is seen as most important in understanding the way that we perceive, think and act.

Sensory subsystems:	
Acoustic:	sound frequency (pitch), timbre, intensity <i>what we hear in the world</i>
Visual	light wavelength (hue), brightness, saturation <i>what we see in the world</i>
Body State	stimulation type, location, intensity <i>what we feel in our body</i>
Perceptual subsystems:	
Morphonological	Abstract structure of sounds, especially speech <i>what we hear in our head, our mental voice</i>
Object	Abstract structure of visual objects, their position and motion <i>what we see in our head, our mind's eye</i>
Central subsystems:	
Propositional	the identities of objects, their relationships, and facts about them <i>what we know as facts about the world</i>
Implicational	ideas about the real ‘meanings’ of events, situations and emotions <i>what we know as ‘feelings’ or ‘impressions’</i>
Effector subsystems:	
Articulatory	force, target positions and timings of vocal and gestural muscles <i>what we intend to say, subvocal speech and gesture</i>
Limb	force, target positions and timings of skeletal muscles <i>what we intend to do, physically.</i>
Figure 2.9: the nine cognitive subsystems, the types of information that they each deal with, and their subjective qualities (italics).	

To understand how people will perceive, learn about, and use an interface design, it helps to think about all of the sources of information that they will be using as their cognitive processes operate. The interactions between the subsystems mean that all of the perceptual and central subsystems are influenced by more than one source of information. The implicational level is built up from a blend of transformations from sensory inputs and the current propositional representation. The propositional representation takes some input from the implicational level, some from the structure of the visual information, and some from the structure of the sound information. Sound is structured according partly to aspects of the raw sensory data, partly from the propositionally-based expectation about what we are hearing, and also partly from the interpretation of the object level, if we happen to be looking at text or other linguistically related information (including lip movements). Similarly, understanding object representations means considering the visual details as well as the contribution of the propositional subsystem.



All perceptual and central subsystems receive representations from more than one source.

In the following sections we will look in more detail at some of the ways that visual information can be used to add structure to an object representation, before moving on to look at the way that propositional information can be blended. This will introduce us to blending at other levels of representation.

•3• How objects form groups

Objects and groups

In the lighting and heating control panels shown in Figure 1.8, objects were grouped explicitly, with boxes. Objects can also be grouped according to their appearance or spatial arrangement. Figure 3.1 shows a similar panel that has no explicit grouping cues. As you can see, though, the names and buttons still do form groups, even though there are no boxes. This means that when you are designing an interface, you cannot simply avoid the question of grouping objects, because if you don't try to design grouping into the interface, the user's perceptual processes will still try to impose a structure on the display - and it might not be the structure you want. In Figure 3.1, the room names and the buttons form vertical groups, similar in structure to the Heating panel. As we saw in Section 1, this might be good for turning all of the ventilation on or off, but not for controlling specific rooms.

The structure of the object representation that isn't explicitly there in the visual information is being added by the visual-to-object transformation, as described in section 2. In this section we will look at some of the principles that affect the way that this transformation process operates to create implicit structure. Many of these principles have been known for a long time, and you might know of them as 'Gestalt' rules.

Figure 3.2 shows how four triangles can be grouped in different ways due to:

- proximity (being very near to each other)
- sharing a colour
- sharing a boundary
- sharing a junction.
- collocation (being superimposed or intersecting)

These are 'physical' relationships that can be derived from the visual information, and in some cases the groups that result appear more 'obvious' than the original triangles.



Visual information can affect the way that objects form groups

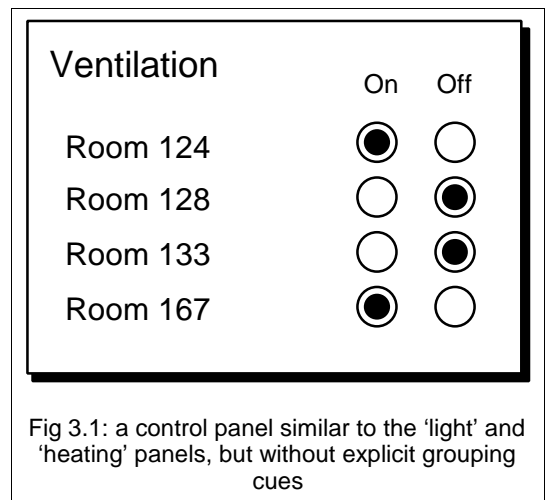

Fig 3.1: a control panel similar to the 'light' and 'heating' panels, but without explicit grouping cues

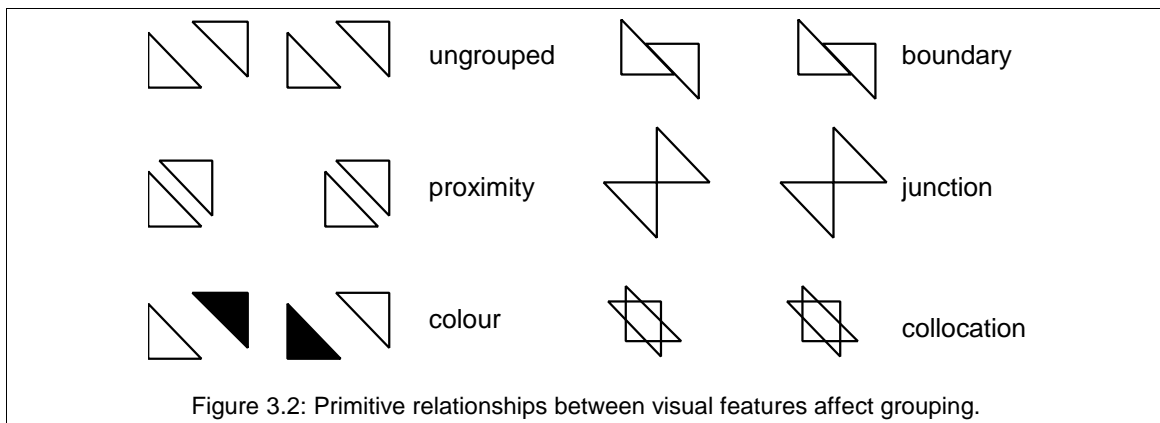
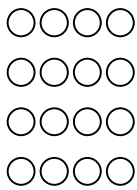

Figure 3.2: Primitive relationships between visual features affect grouping.

If you had to describe the 'junction' or 'collocation' parts of this figure, without having seen the rest of it, you would probably not make any mention of triangles. Instead of calling the junction group 'two triangles joined at one corner', you might call it 'an hour-glass' or 'a bow-tie'; and you might call the collocation group 'a six-pointed star, slanting backwards'. In both of these instances, you are describing the 'group' that is composed of the two triangles, and not the triangles themselves. We can take this point further still, because even in the 'ungrouped' instance, we perceive 'triangles', and not individual horizontal, vertical and oblique lines. In terms of the basic processes of visual perception, it is even arguable that we actually 'see' lines as 'end-points', 'corners' and 'middles' - but while this may be what we 'see' in our visual representations, it is clearly not what we 'perceive' with our object representations.

Exercise Set 1

Draw structure diagrams for these sets of objects – start each with a group called ‘set’ at the top level of the structure and use up to four levels. Describe the visual attribute that ‘causes’ each group.



(1)

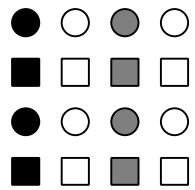

(2)

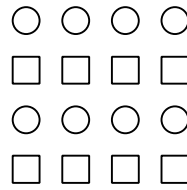

(3)

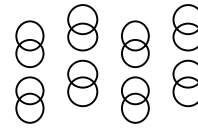

(4)

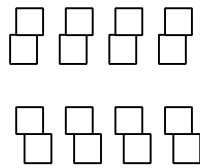

(5)

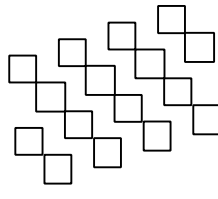

(6)

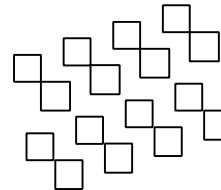

(7)

Psychological Subjects pop-out

One way to approach the problem of deciding when objects form groups and when they don't is to consider the phenomenon of ‘pop-out’. This happens when there are several objects forming a group, and one object that doesn't join the group. In Figure 3.3, for example, there are three groups of circles. If you just look at the left hand group, all of the circles are exactly the same, and none of them stand out any more than the others. Because of their ‘proximity’, they are all members of the same group, and if we were to draw a structure diagram, each circle would be represented at the same ‘level’ of the structure as the others (shown in the left hand part of Figure 3.4).

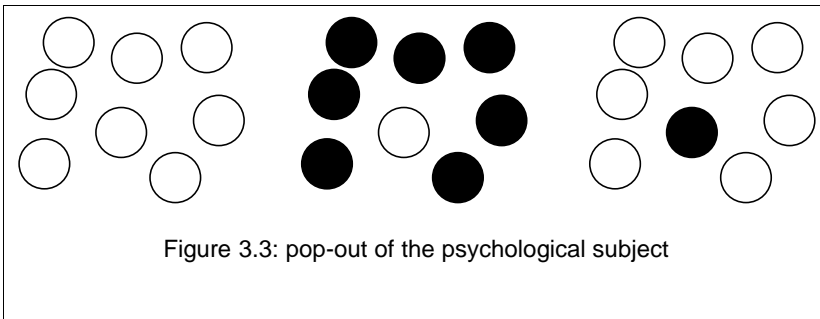

Figure 3.3: pop-out of the psychological subject

The central and right hand groups are different. In these groups all of the circles are the same size, but one of them is a different colour. You have no difficulty in

noticing which one it is, because it seems to ‘pop-out’ from the others – and the structure diagrams for these two groups, shown in the central and right hand parts of Figure 3.4, represent this.

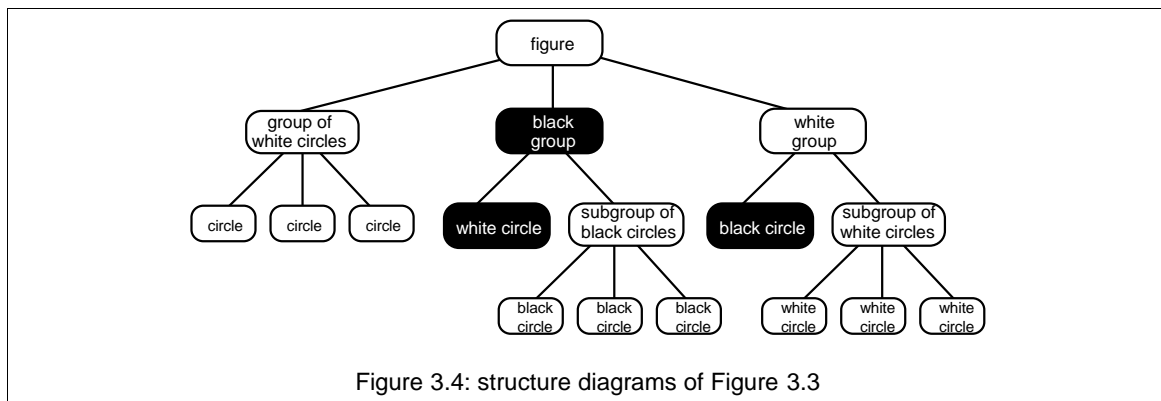

Figure 3.4: structure diagrams of Figure 3.3

The circles that share the same colour all form a subgroup, to which the different circle does not belong. Both the subgroup of similar circles and the different circle are part of a larger group, and so we see them as related, but when we focus on the whole group to see the objects that it is made up of, we perceive the single circle and the group of circles.



Objects that are spatially close to a group, but not part of it, seem to ‘pop-out’

If we drew a transition path diagram for someone viewing the central group, we would show them attending to the Figure as a whole, with the central group as their psychological subject. This would be followed by a transition to its structure that made the white circle the psychological subject, and the subgroup of black circles its predicate. In this case, the effect of pop-out is so strong that it almost forces the viewer to make the white circle the subject as soon as they attend to the structure of the central group. Even if the viewer wants to look at one of the black circles, they have to attend momentarily to the white circle, and then make additional transitions to the subgroup, and then into its structure to find a black circle. It doesn’t matter whether the odd-one-out is black or white: as long as it is different, it becomes the psychological subject and pops-out, simply *because* it is different. As with the triangles in Figure 3.2, there is nothing in the sensory information that explicitly tells us that the black circles in the central part of Figure 3.3 all form a group, to which the white circle does not belong. At a visual level, they are all just areas of varying colour. The structural information that relates them together as members or non-members of groups is added by the process that transforms the visual representation into an object representation.

If four of the circles in a group were black and four were white, then there would be two equally sized subgroups and neither would pop-out. If there were subgroups of five and three circles, the effect would not be as strong, but it is likely that the smaller subgroup would form the psychological subject, and the larger group would be its predicate. The visual-to-object transformation ‘favours’ the part of the visual scene that is different, and produces representations organised with them as the psychological subject.

In Figure 3.4 we have drawn the ‘different’ circle in each group in white text on a black background, to show that it pops-out. At the level above, we have indicated that the ‘black’ group pops-out in the same way, because it is different in ‘colour’ to the other two groups. When you look at the ‘whole figure’, the black group pops-out; but once you have attended to it, its white circle pops-out. Of course, it isn’t just colour that can make things different to their neighbours. Figure 3.5 shows that pop-out can also happen for shapes.

Again, it doesn’t matter why the shape is ‘different’. You might say that the oblongs are all the same, and have just been rotated, but this is enough to make them different in the visual representation. As long as a shape is different, the visual-to-object transformation picks it out as the psychological subject, and the other objects form a group that becomes its predicate. If you think about looking for objects in the real world, this bias of perception makes sense: more often than not we are searching for objects against a background, looking for one particular object that is different to the rest of the scene. Whether it is a ripe red apple in a tree of green leaves and green apples, or an icon on a computer screen, it often has some visual feature that makes it stand out from the background.

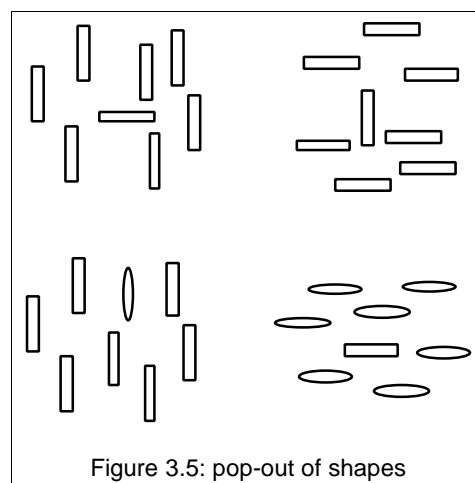

Figure 3.5: pop-out of shapes



The **pragmatic subject** is the object that will become the psychological subject when the structure of its group is attended to, because of its visual features..

While higher mental processes could spend time and energy making transitions through a representation to locate the correct object, it is generally economical for the visual-to-object transformation to pick up the implicit information from the sensory data and to make the odd-one-out the one that gets attended to first. We make use of this tendency in the transition path diagrams, by drawing the psychological subject against a black background: it immediately pops-out from the diagram and orients you to the part of the Figure we are likely to be describing. We have also been using this convention in the structure diagrams, to indicate an object that pops-out to become the psychological subject. Unlike the transition path diagrams, which indicate the object that actually is the psychological subject at any moment, the structure diagrams aren’t showing ‘processing’, but just the structure. The objects that pop-out aren’t always psychological subjects, but will be if their level is attended to. To distinguish these ‘potential’ psychological subjects from ‘actual’ psychological subjects, we’ll use the term ‘pragmatic subject’ – this means that the object can be expected to become the psychological subject for pragmatic reasons.

Exercise Set 2

1. Draw transition path diagrams for Figure 3.3, showing the transitions that are needed to look at a white circle in each subgroup (you can base them on the structure diagrams from Figure 3.4).
2. Draw a structure diagram for Figure 3.5, indicating which object forms the pragmatic subject of each group.
3. Using this structure diagram, make transition path diagrams to show how a 'horizontal oblong' would be located in the first, second and fourth group (there isn't a horizontal oblong in the third group!)

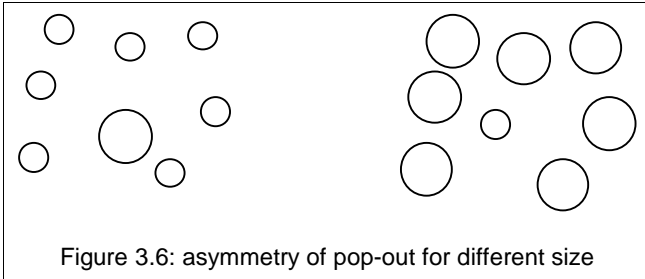

Figure 3.6: asymmetry of pop-out for different size

(Figure 3.7). To make the small circle the psychological subject, a transition from the group is needed. While colour and orientation were symmetrical (black and white being equally able to pop-out) and it was an object's 'difference' that was the cue, here the attribute is 'asymmetrical', and the visual-to-object transformation always favours the larger-sized objects.

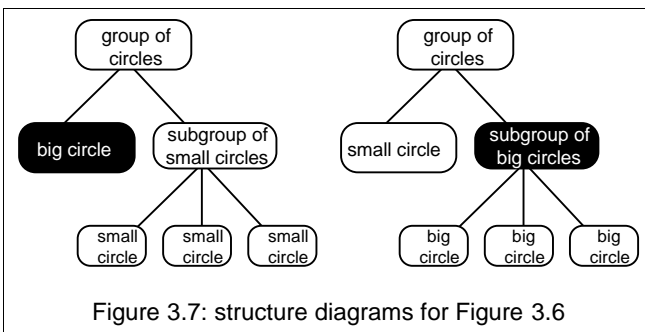

Figure 3.7: structure diagrams for Figure 3.6

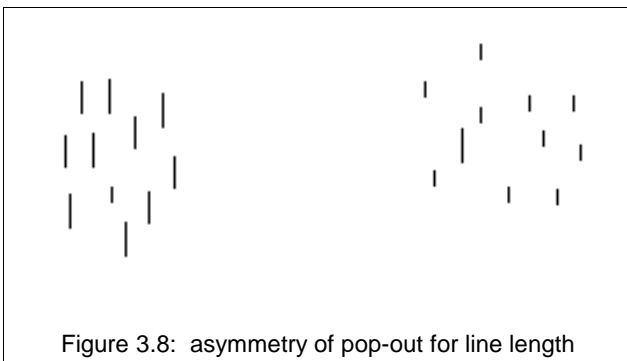

Figure 3.8: asymmetry of pop-out for line length

Pop-out of groups

Colour and orientation aren't the only sensory cues that the visual-to-object transformation can use to pick out part of a scene as a pragmatic subject. Other attributes can also be used – but in a different way. In the two arrays in Figure 3.6, the size of the circles is varied.

Although it is still easy to find the small circle among the big ones, it is not quite as easy as finding the big circle amongst the small ones. The big circle amongst the little circles is the pragmatic subject of its array, but the group of big circles is the pragmatic subject of the other array.

The same asymmetry can be seen with the length of lines in Figure 3.8. The reason for this asymmetry is that the size of a visual object is related to its closeness to us – in general, the larger an item is, the nearer it is. The visual-to-object transformation is now choosing the closer object as more likely to be of interest, and so makes it the pragmatic subject. Again, this seems to make sense in terms of the real world: if you are in a tree picking apples, the ones that are visually larger are more likely to be within reach than the ones that are visually smaller. The same rule of thumb applies to contrast and brightness, since as things get closer to us they reflect more light, and are less obscured by anything that is in the air.

In many situations computer interface designs can take advantage of this bias towards difference and nearness. Like the white-on-black convention that we have adopted for representing the psychological and pragmatic subject, words and icons that are 'selected' usually become highlighted in some way, partly to provide feedback about the selection, but also to make sure that the user is actually attending to the part of the display that they have acted on.



Objects or groups that are larger or brighter appear **nearer** and can be pragmatic subjects.

Options on menus and in dialogues that are unavailable are shown 'greyed out' by reducing their contrast – this indicates their unavailability, and also makes them less likely to be attended to, since they will no longer form part of the group that is the psychological subject when the menu or dialogue is viewed. In Figure 3.9, for example, a set of commands that operate on Tables in a word-processor are greyed out when the user has selected an ordinary paragraph of text – the other

paragraph formatting commands are still black, and so they form a pragmatic subject that immediately grabs the user’s attention.

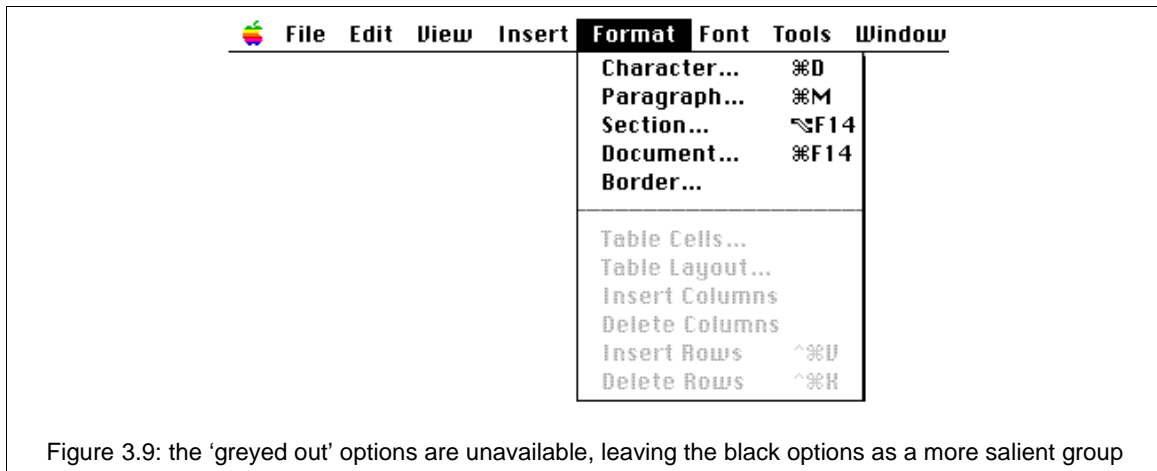

Figure 3.9: the 'greyed out' options are unavailable, leaving the black options as a more salient group

Use of these attributes can also help people to discriminate objects by guiding their attention to the part of its structure that distinguishes it from other objects. Figure 3.10 contains an array of four abstract icons, each of which is made of a diagonal cross and an upright cross. In (a) both crosses are shown by lightly dashed lines, but in the others one of the crosses is drawn as a bold, solid outline. Looking at each icon in turn it is clear that these changes affect the way that they are interpreted.

The icon (a) could be seen as two dashed crosses superimposed on one another at an angle, as four dashed lines, or as an eight pointed star. To its right, icon (b) has one dashed cross and one solid diagonal cross – the size of this cross makes it more salient, as it forms the pragmatic subject and the dashed upright cross becomes its predicate. The next icon, (c) has the same visual structure, but has been turned through 45°. This change in orientation is sufficient to render this solid, upright cross as an object that is different to the solid, diagonal cross of (b). Finally icon (d) has a large black diagonal cross – again the size of the diagonal cross makes it the pragmatic subject of this icon, but its colour also makes the icon that it belongs to likely to form the pragmatic subject of the whole array.

If this array is attended to, it is probable that (d) may be the pragmatic subject, as its black solid cross is both 'nearer' than the thinner dashed crosses and 'different' to the solid, white crosses. The nature of the group of crosses that is icon (d) is defined predominantly by the nature of its pragmatic subject – because if it is looked at, the pragmatic subject is the first part of its structure that will be attended to.

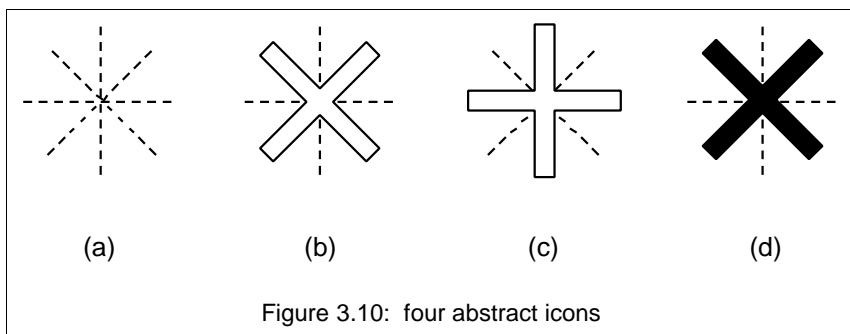

Figure 3.10: four abstract icons



The 'appearance' of an object is determined by its pragmatic subject

Exercise Set 3

1. Draw transition path diagrams for the location of a big circle and a small circle in each part of Figure 3.6.
2. Draw structure diagrams for both parts of Figure 3.8, and transition path diagrams for the location of a small and a large line in each part.
3. Draw structure diagrams for each of the icons in Figure 3.10.
4. Draw transition path diagrams for Figure 3.10, showing the transitions necessary to attend to the diagonal crosses of each icon. Which cross is hardest to attend to?

•4• Searching through structures

Pragmatic Subjects and Icon search

As the number of icons on an interface increases, and the range of functions that have to be represented proliferates, there is a tendency to design the icon to 'represent' the function in an almost pictorial way. This has a clear advantage when the icon is presented to users on its own, because it is easy for them to 'see' the relationship between the icon and its function (Figure 4.1). What is not so clear-cut is the effect upon the icons 'findability'.

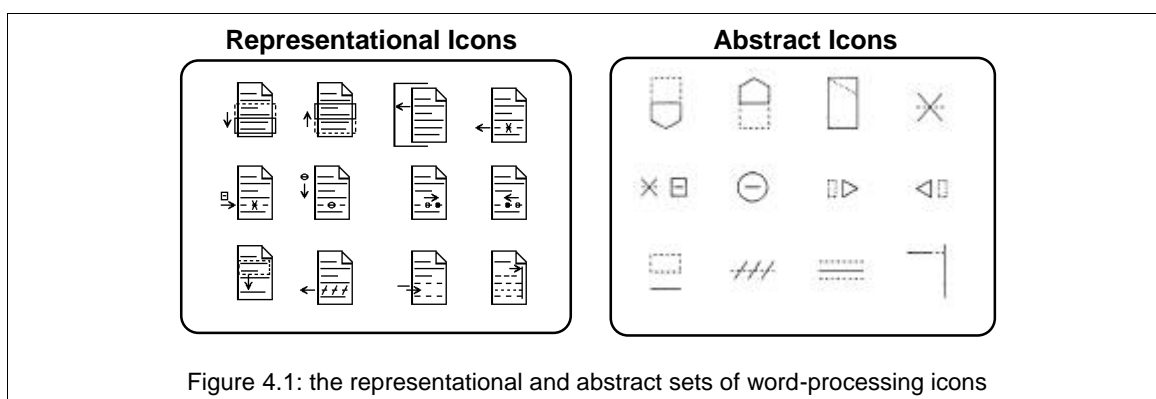
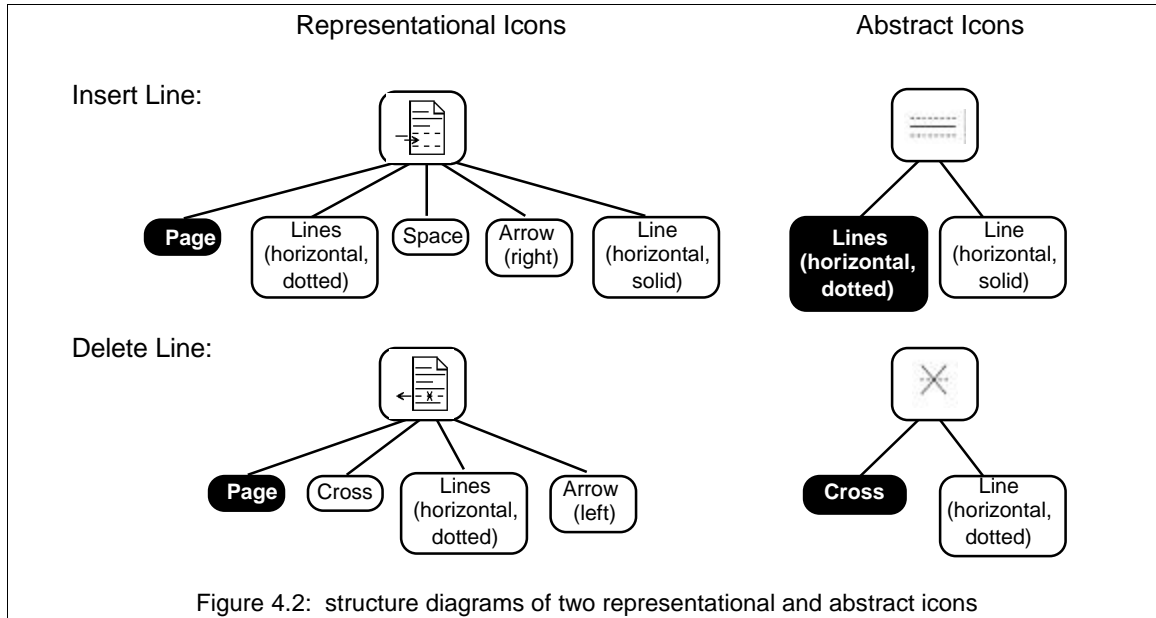

Figure 4.1 shows representational and abstract icons that have both been used to stand for the same set of word-processing commands. The representational icons all look like pages of a document, with lines of text and arrows or boxes indicating the result of their function. The abstract icons are much simpler, and although they too provide some sort of semantic link between their appearance and their function, you really have to know what the possible functions are to work out what each icon might do. This sort of information, of course, is represented at a propositional level.



In experiments where the position of the icons in the array varied, people using the representational set took longer to find the one they wanted than did people using the abstract set. If the icons were kept in the same position from trial to trial, so that users could remember the rough location within the array of each icon, and could 'look' straight for them without searching, the differences between the icon sets narrowed markedly.

The structure diagrams in Figure 4.2 show four of the icons from Figure 4.1: the two from each set that represented 'insert line' and 'delete line'. The icons from the representational set clearly have a more detailed structure than the icons from the abstract set, but they also have the same pragmatic subject as each other. To tell them apart, the user has to attend to their predicate as well as to the subject.

When the time that it took people to find each icon was compared with its internal structure, a clear relationship was found (Figure 4.3). The greater the degree of similarity that the icon's structure had to other icons in its set, the longer it took to find an icon. This suggests that users use their propositional-to-object transformation to access their knowledge about the icon, or about its meaning. This provides them with an object level mental image of the 'target' icon that they are looking for, and they can then compare 'candidate' icons from the array with this internal mental image to see if they match.

An icon in an array would be a candidate if it had the right pragmatic subject, and it would match the target if it also had the right predicate. Icons that needed more objects of their predicate to be evaluated to be discriminated from other potential candidate icons would take longer, overall, to locate.

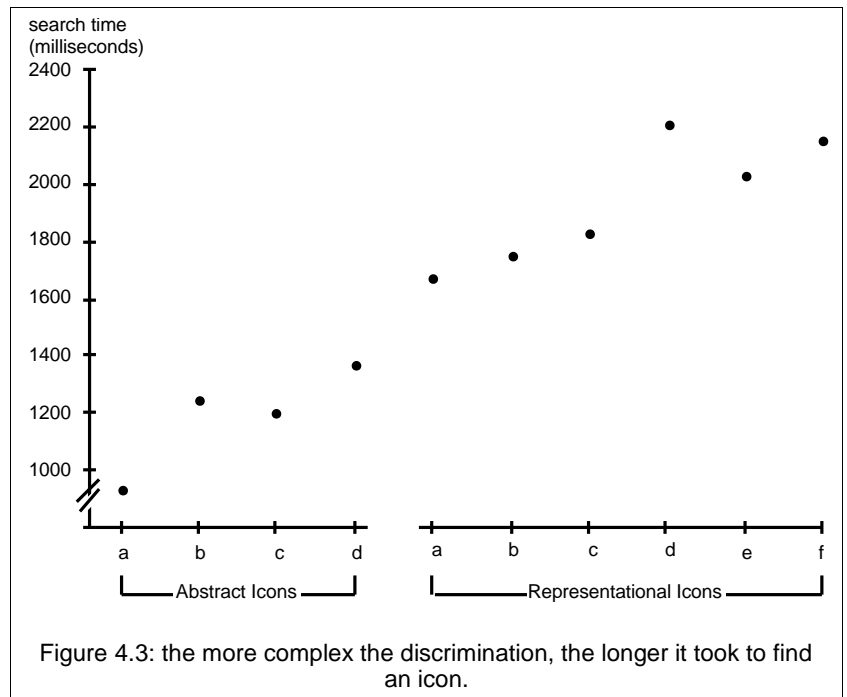

Figure 4.3: the more complex the discrimination, the longer it took to find an icon.



People can search for a target rapidly by looking for objects that have its pragmatic subject

This helps explain why the representational icons took longer to find – it wasn't because they were representational, but because they were all so similar – and even within the sets, it was possible to show that the more complex the discrimination, and the more candidates that shared its pragmatic subject, the longer it took to locate an icon. In the abstract icons the pragmatic subjects are mainly different, which means that the search can be carried out at the level of the icon, using the more salient information. You might remember a similar effect of the pragmatic subject from the very first figures in this guide (Figures 1.1 and 1.2). Figure 4.4 again shows an array where all the icons in the window have different pragmatic subjects.

These icons form a group of icons in an array, but their visual structures do not lead the user to see them as forming any subgroups. When an icon is searched for in this array, the icons can be discriminated from one another by their pragmatic subjects, without their structure needing to be evaluated. As you look from icon to icon in this array, you make the visual transitions represented in Figure 4.5.

None of the icons in this array have any real advantage over each other: if you 'know' what icon you are searching for, and can form an 'object' image of the target, then you can probably locate it quite rapidly. Try finding the icon in Figure 4.4 that looks like a dog sitting next to a Macintosh computer.

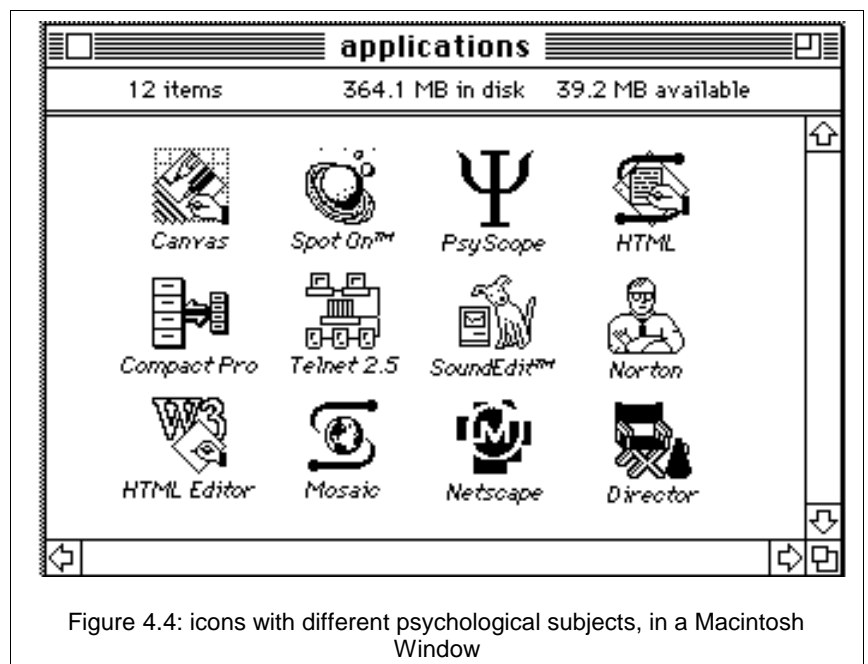
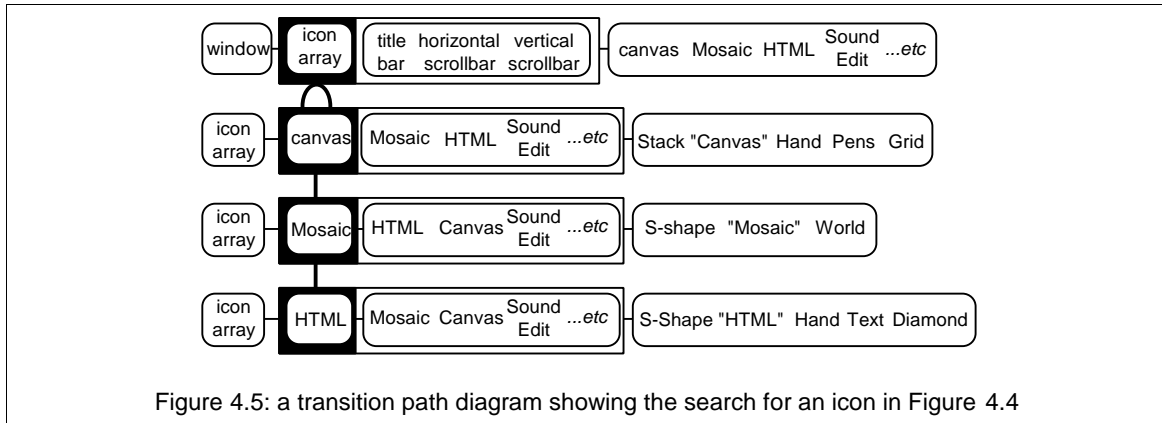
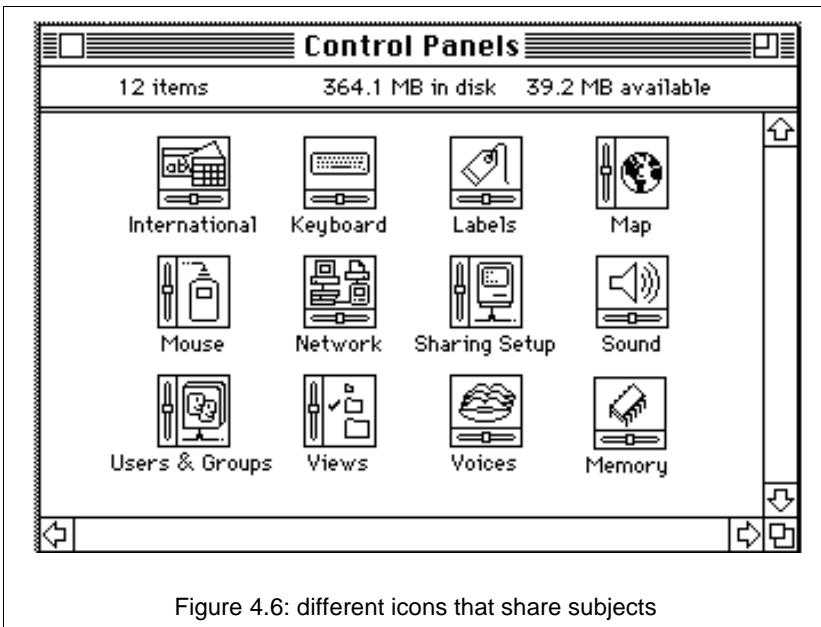

Figure 4.4: icons with different psychological subjects, in a Macintosh Window



In contrast, try finding the icon in Figure 4.6 that contains a picture of a Macintosh computer. Now the subjects of many of the icons are similar, and you have to evaluate more information about each icon, as with the representational icons of Figure 4.1. The corresponding transitions are shown in Figure 4.7.



The pragmatic subject of each icon is the 'slider box' that surrounds each icon's contents, and so it is not possible to ignore them and locate the Macintosh directly. Each time an icon is attended to, a transition must be made away from the pragmatic subject to examine the rest of the icon's contents. Again, none of the icons have much of an advantage over each other, but this array is harder to search than the one shown in Figure 4.4, because more transitions are required to search through its structure. In Figure 4.7, three icons are searched before the correct one is found – with 12 icons, the average number of icons that would be evaluated in this way would be 6.5!

As with the circles of different colour, and the lines of different orientation, when one

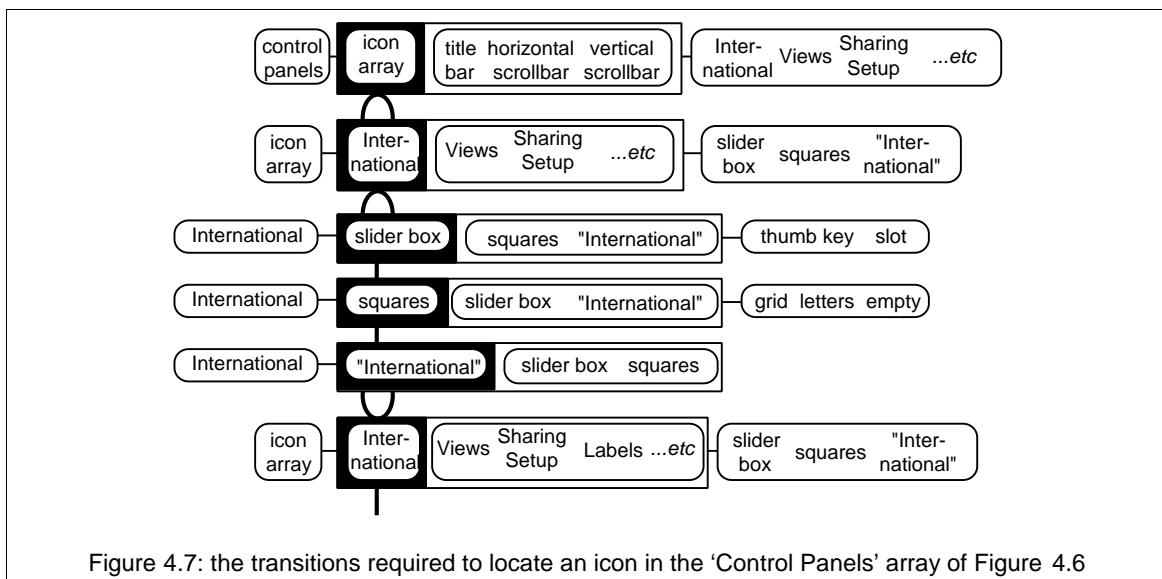

icon in an array has a completely different pragmatic subject to the others, pop-out happens, and that particular icon is very easy to find - this is shown in Figure 4.8. The icon that does not belong to the group of 'Word' document icons pops out from the array. Even though the Word icons are not all identical, and have different text labels, they are difficult to search through. The Word icon that is 'different' to the others still has the same subject (the document shape) and also shares a predicate object (the large 'W') and so is nothing like as easy to locate as the 'ψ' icon.

To summarise, if you are designing an array of icons that people will have to search frequently, it is sensible to give them different pragmatic subjects, rather than different predicates. However, having different pragmatic subjects will make the icons 'look' different, and so the array itself might be harder to pick out.

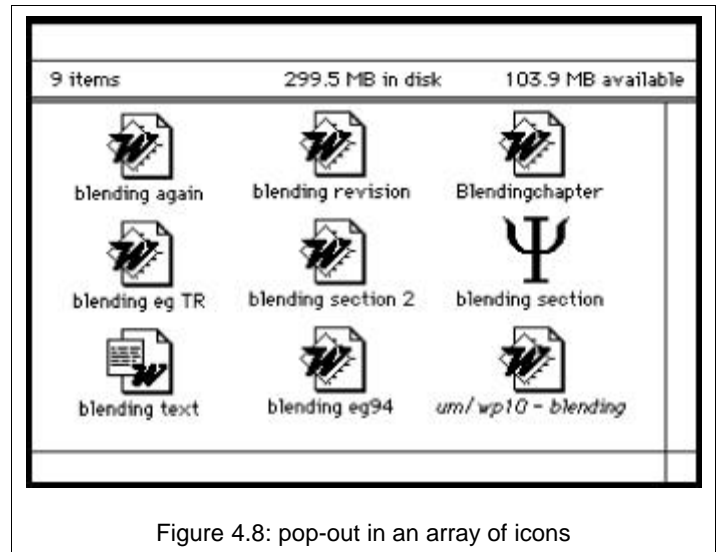

Figure 4.8: pop-out in an array of icons

An object's structure affects grouping

The examples of pop-out we have seen so far have shown that changing one attribute of an object can affect the structure of the scene, by determining which other objects it will or will not form a group with. As well as changes to attributes, changes to an object's own internal structure can also affect grouping: structure affects structure!

The arrays (a) and (b) in Figure 4.9 contain two types of object. One is a simple circle, the other is an incomplete circle – a small part of the circumference is missing. When the incomplete circle is placed amongst an array of complete circles (a), it is easy to see the incomplete circle. The opposite is not true – in array (b) it is much harder to locate the complete circle amongst a number of incomplete circles.

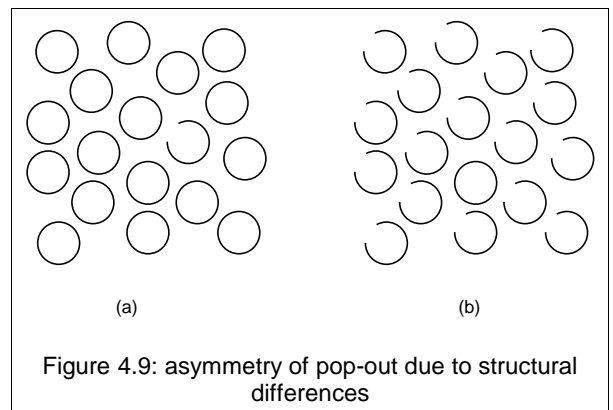

Figure 4.9: asymmetry of pop-out due to structural differences

When we draw structure diagrams for these two sets of circles, we have to show the incomplete circle in set (a) forming a pragmatic subject, to make it clear that it pops-out. For set (b), we have to show the complete circle as part of the same group as the incomplete circles, because it doesn't pop-out. Figure 4.10 shows how these groups are composed (not all of the circles are shown). In the Figure we have described the incomplete circles as 'circles plus gaps' – in effect, we are saying that they actually have two components to their structure, while the complete circles are just circles, and have no further structure.

When most of the objects within a group are simple, and do not have a structure, a similar object that does have a structure cannot form a group with them at the same level. The simple objects form a subgroup, and the complex object becomes a pragmatic subject, as in Figure 4.9(a). In contrast, when most of the objects within a group are complex, with a common pragmatic subject and a structure, simple objects that consist of the same pragmatic subject but nothing else, are able to join the group: as in Figure 4.9(b), they are simply perceived as similar to the other objects, but less complex. They are able to 'hide' amongst the noise of the other objects' complexity.

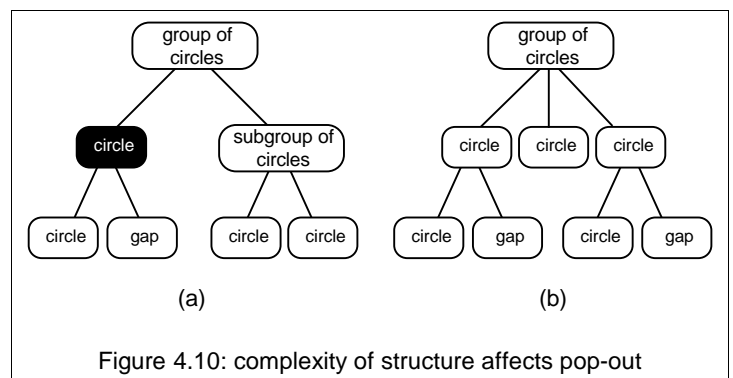

Figure 4.10: complexity of structure affects pop-out



Complex objects that do have a structure pop out from simple objects that do not have a structure.



Simple objects can 'hide' amongst more complex ones, if they have the same pragmatic subject.

Exercise Set 4

1. Draw structure diagrams for each of these abstract icons (ignore the words):

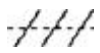

delete line



word search

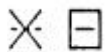

replace word



scroll right

2. Draw a structure diagram for the array of icons in Figure 4.8 (ignore the text labels and the 'frame' of the window), with the 'document shape' as the pragmatic subject of the icons that have one.
3. Draw another structure diagram for the icons in Figure 4.8, this time assuming that the 'W' of each icon was its pragmatic subject.
4. On the basis of the two diagrams you have drawn for Figure 4.8, would it be easier to find the 'blending text' icon if it had the 'document' or the 'W' as its pragmatic subject?

•5• The role of knowledge

Knowledge can affect structure

We have now seen that structural information can determine pragmatic subjects – it isn't all to do with lines and colours. Pop-out also occurs with items whose size, shape and colour are the same, but whose structures are different, as in Figure 5.1(a). The 'cube' that points the 'other way' stands out. You might think that this is just because it has been rotated, but there is no pop-out with similar objects that contain the same number of lines, angles, and so on, as in Figure 5.1(b).

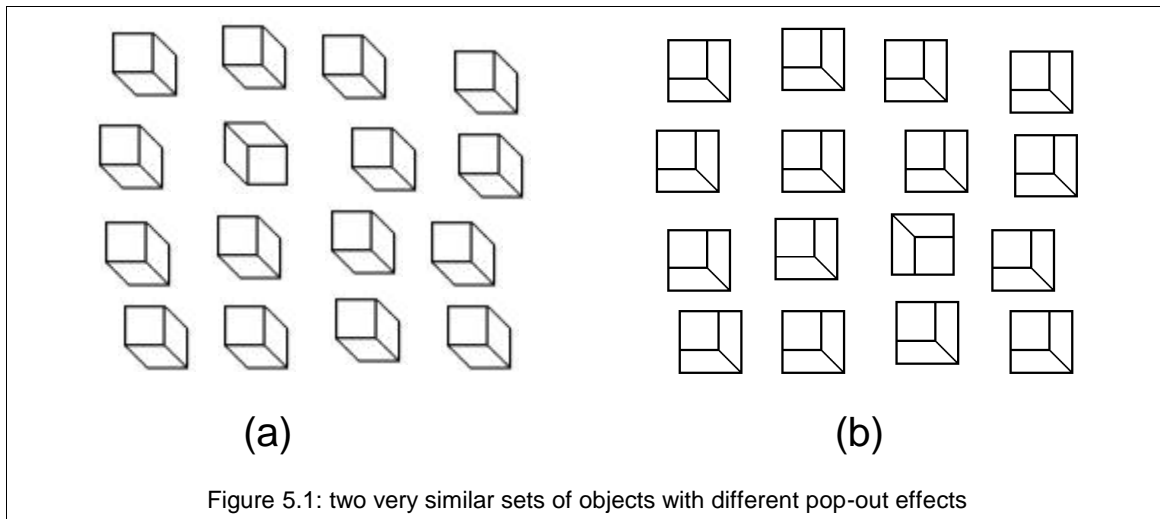

Pop-out for the objects in Figure 5.1(a) must be due their grouping in the way that is shown in Figure 5.2. Lack of pop-out for the objects in Figure 5.1(b) must be due to their forming a single group, which needs to be searched through for the 'different' object to be found.

This is a good example of how the propositional knowledge that a person has access to can affect how they perceive the display. If you are told that the objects in Figure 5.1(b) show the end of a megaphone, or an empty box 'descending' into the display (as in Figure 5.3), then you can form a mental image of a three-dimensional depth relationship between the lines on the screen. Nothing has changed visually, but now the one item 'facing' the other way pops out of the display.

Seeing it as three-dimensional has made its 'direction' obvious, and it has been grouped separately from the other 'empty boxes'. You have almost certainly seen lots of pictures of cubes like those in Figure 5.1(a), and so you were able to see them as three-dimensional straight away, but the use of perspective in the objects of Figure 5.1(b) is unconventional, and so you had to be given a hint as to how to interpret them as three-dimensional.

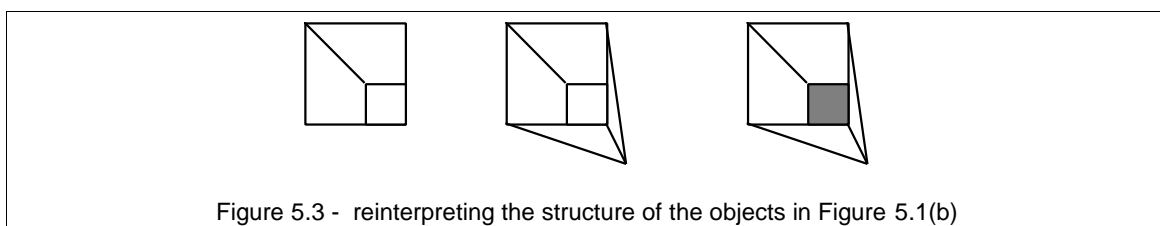
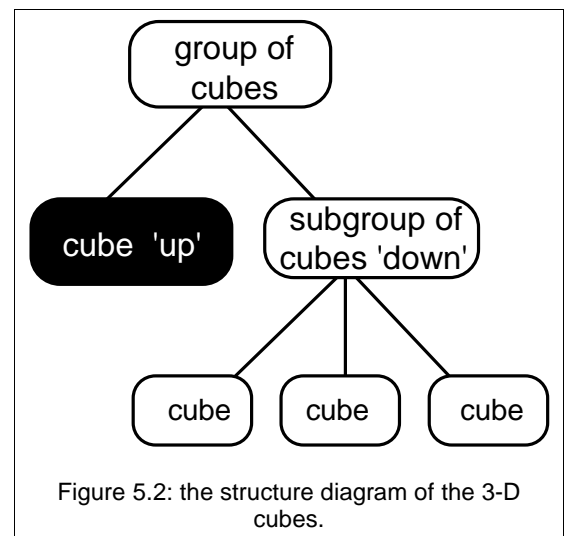

Exercise Set 5

1. Draw the structure diagram for Figure 5.1b, showing the representations formed without any propositional knowledge, so that objects are perceived as 2d.
2. Draw the structures with propositional input, so that they are perceived as 'empty boxes'. Which object is the pragmatic subject?
3. Look back to the structure diagrams that you drew for questions 2 and 3 in Exercise Set 4 (for the document icons). Which of the document icons is the most 'complex'?
4. Draw structure diagrams for these two arrays of icons, and identify which icon, if any, is the pragmatic subject:



Learning the meaning of objects

A computer user who was searching through the abstract and representational icon arrays of Figure 5.1 had to generate mental images of 'target' icons that they then compared the 'candidate icons against. Before the experiment could begin, the users had to learn what each of the icons 'meant' – propositional knowledge. When they were then asked to 'find the icon for *delete line*', they were able to retrieve their propositional knowledge and use it to generate an object representation of the icon that they were looking for, without any visual information.

In practice, users can never be given exhaustive training on computer programs, to make sure that they know exactly what every icon looks like and means, nor what the structure of every dialogue box is going to be. What users will learn about the structure of interface objects depends on how they use them, as was shown by two hypertext databases that used versions of the same display design, with one slight difference (Figure 5.4).

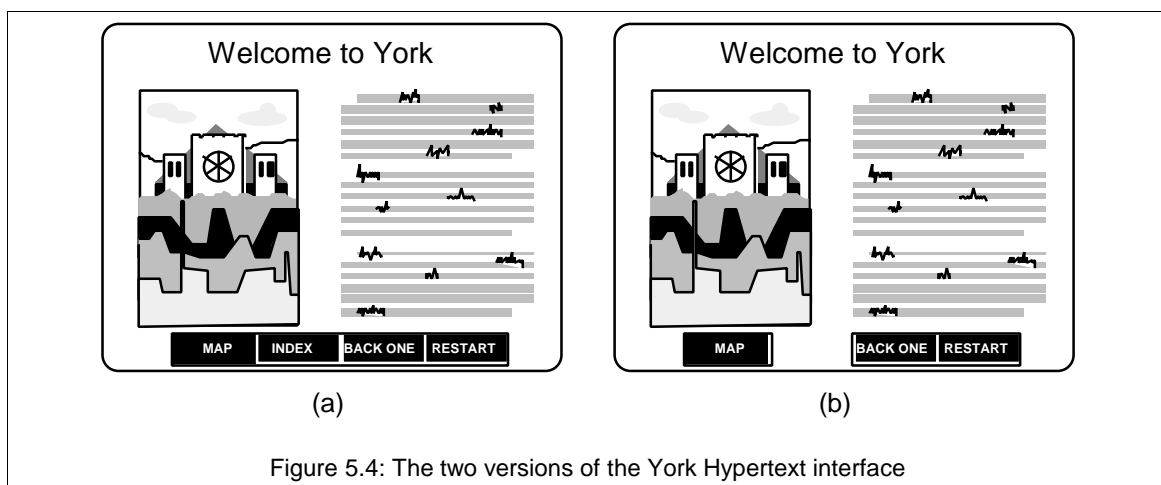

Figure 5.4: The two versions of the York Hypertext interface

The prototype 'visitors guide' had been built to let people read text and see pictures of York. They could navigate by clicking on 'hot spots' in the text, or by using a set of buttons at the foot of the screen. In Version A of the interface, these buttons allowed them to access a schematic 'map' of all of the screens, an alphabetic 'index' of the screens' titles, to go

'back-one' to the previous screen they had seen (rather like an undo function), or 'restart' to go right back to the first screen.

Version B was the same, except that the 'index' button was omitted. People were shown how all of the functions worked, and then given some questions about York that they had to find the answers for in the hypertext. A typical pattern of exploration involved the users selecting a screen, and then realising that it didn't offer them any help, and so they would use the 'back-one' button to retrace their steps. Sometimes they would get completely lost, and 'restart'.

In Version A the navigation buttons were presented together as a block at the bottom of the screen, and since they had similar shapes and colour, they formed a group on the screen (Figure 5.5). To attend to any one of these buttons, people first had to attend to the group as a whole, and then make a transition into the group's structure.

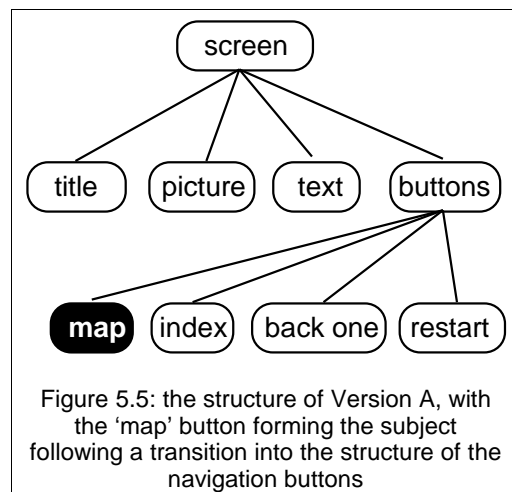

When they did 'zoom in' to the structure of the groups, the individual objects were the four buttons, but since they were all identical (apart from the textual labels), none of them 'popped out' as a pragmatic subject according to shape or colour. In these circumstances, users would be most likely to scan across the buttons from left to right, reading the labels as they would normal text. A transition path that would be required to find the 'restart' button in this interface is shown in Figure 5.6.

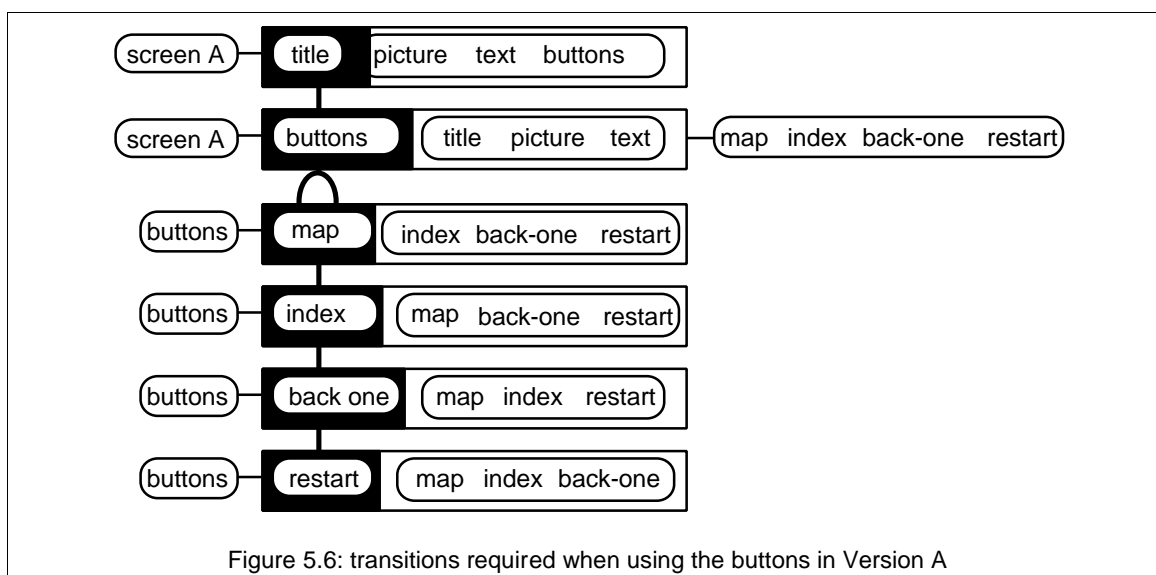

After people had answered all of the test questions, they were asked about the various functions and buttons, and what they all did. Most of the people who had used Version A were found to understand that the map and index buttons could help them navigate around the system, even if they had not actually used them (they had, after all, been shown them in the introduction). Surprisingly, the people who had used version B were found to have less knowledge about the purpose and use of the 'map' button. A look at the structure of the interface shows why this might be (Figure 5.7).

In Version B, the gap left by the omission of the 'index' button breaks up the group of navigation buttons. Now the 'map' button stands on its own - and depending upon the size of the picture, might actually be associated structurally with it instead of with the other buttons. When people had to use 'back one' or 'restart', they no longer had to encounter the 'map' button (the transition path is shown in Figure 5.8). This meant that as they used the system, they did not encounter the 'map' button while they were navigating, and so the information they had been given at the start of the session about its function was not integrated into their propositional understanding of the system's functionality.

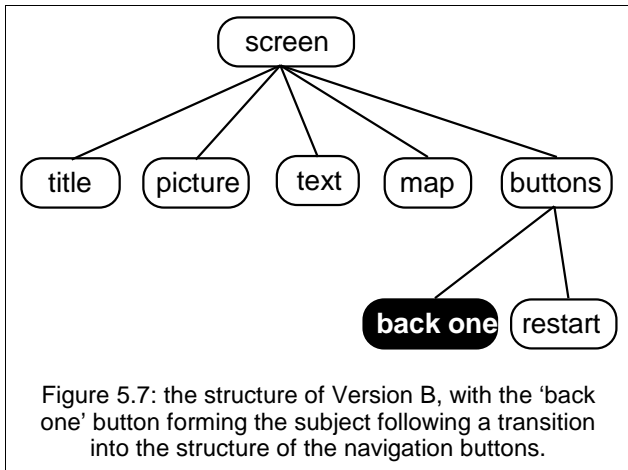

The transition path diagram for Version B shows that it is indeed easier for the users to find and use the back-one and restart buttons, but it is at the cost of their understanding of the map button. A conclusion we can draw from this example is that grouping items together visually not only helps users to locate them *as a group* when they need to use them, but it also helps them to generalise about their common functionality.



Objects that are grouped together can come to share propositional meaning, with experience

Propositional knowledge about one of the group will tend to 'rub off' on the others. Of course, this can only be beneficial to users if there really is some similarity in the functionality of the grouped buttons. If the 'map' button had actually shown a geographical map of York, rather than of the hypertext, it would not have helped them to navigate around the system at all, and so it would have been misleading to

place it with the other navigation buttons, even though they are all 'objects the user can press'.



Functionality is 'what the user does with a system', not 'what the system could do'

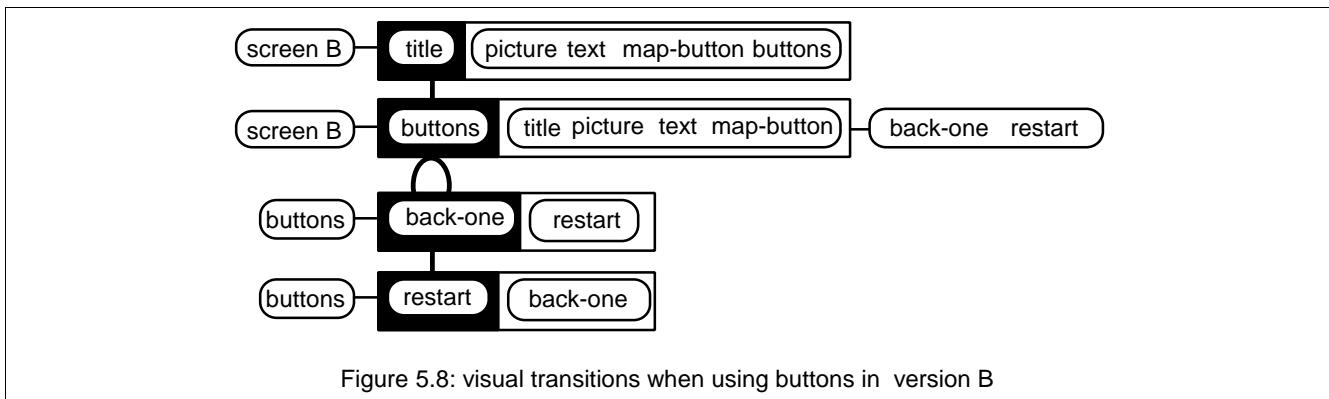

Competing groupings

The contribution of propositional knowledge to perception might seem to make the task of display design a whole lot easier: after all, if users can be told what to look for, and can learn how to group objects, why should it matter what the visual information is like? The pop-out examples shown earlier in this guide should convince you why this argument fails: for example, even when you know that all of the circles are just circles, a differently coloured circle still pops-out.

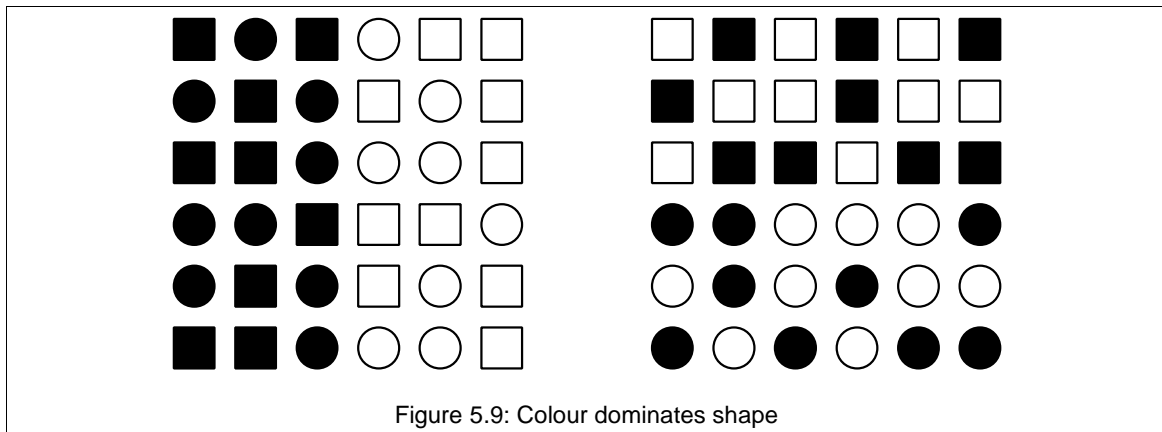

Those examples were selected especially because they showed the effects of pop-out very strongly, of course. They were generally very simple, with only one attribute changing to influence grouping. Even in more complex arrangements, the dominance of the visual contribution to object representations can be just as convincing.

The left hand array in Figure 5.9 shows again how strongly colour can determine the grouping of objects. It is easy to see this as a group of black objects and a group of white objects, even though the objects themselves have different shapes. In the right hand array, where the objects are arranged by shape, it is not so easy to see two distinct groups.

Here the randomness of the colour dominates the orderliness of shape, preventing the visual-to-object transformation forming a pragmatic subject in the structure of the array. Figure 5.10 shows structure diagrams of the two arrays. In the left hand array, there is an ‘intermediate’ level of grouping between the array and the individual objects, but this is missing in the right hand array. Once you ‘know’, propositionally, that there are two ‘shape’ groups in the right hand array, you can impose this structure on the object representation, but it seems to require continual mental effort to do so. As soon as you look away and back, the randomness of the colours dominates once again.

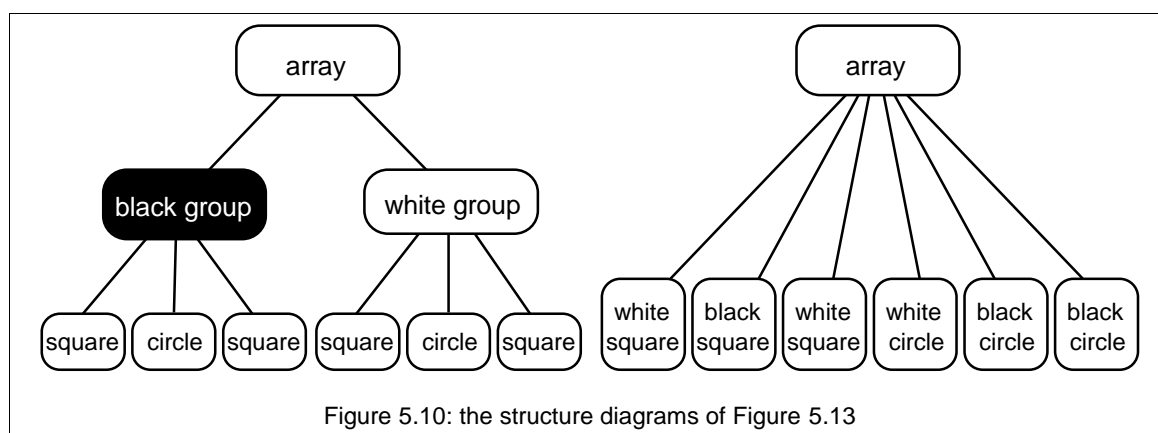

The arrays (a) and (b) in Figure 5.11 show pop-out due to the shape of the oblongs. In both (a) and (b) the object in the array that does not have the same shape as the others becomes the pragmatic subject and pops out. In (c) one object differs in colour, and the pop-out effect is enhanced. As in Figure 5.9, colour is stronger than shape, for in (d) the white, horizontal object pops-out, while the black, vertical form does not. This is despite the fact that the white object has the same shape as the black objects, while the black object has a different shape: so colour dominates shape.

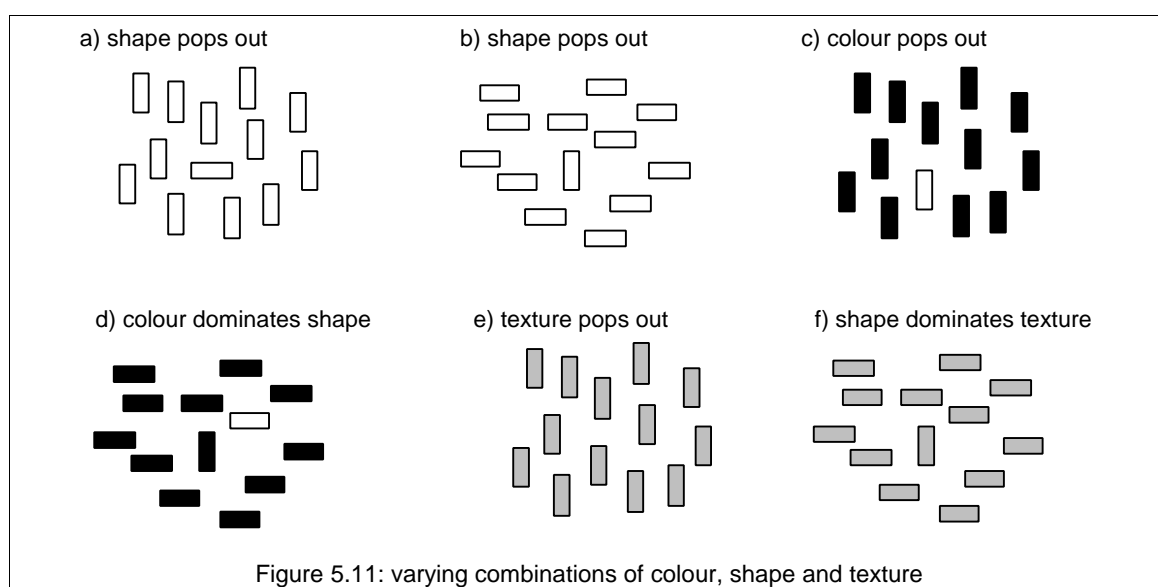

Arrays (e) and (f) introduce a new attribute, texture. Texture is defined as a regularly spaced, repetitive pattern where each of the objects of the pattern is individually perceptible, but where the objects are much smaller than the whole that they fill. Although it is common to think of texture and colour as very similar, since they appear to be properties of the surface of objects, visually they have quite different properties. Unlike colour, texture does not dominate shape.

In (e) the oblong with a different texture (direction of stripes) to the other oblongs does pop out weakly, but in (f), the upright oblong that has the same direction stripes as the other oblongs stands out instead. There is a horizontal, differently textured oblong in the array, but it is much harder to locate now than in (e). Clearly the ‘difference’ of the texture is not as influential as that of colour. Like size, brightness and contrast, texture is also a ‘depth cue’, with objects of a finer texture appearing further away than objects of a coarse texture (Figure 5.12).

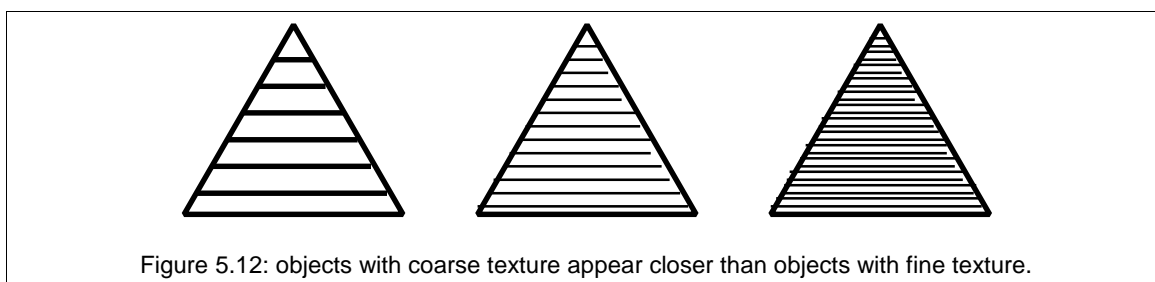

Figure 5.12: objects with coarse texture appear closer than objects with fine texture.



A coarse texture, like a larger size and increased brightness, makes an object look **close**.

Although the textures in Figure 5.11 were differently sloped, they were equally bright, and so they did not suggest that any of the oblongs were any nearer or further away than any of the others. This meant that the texture attributes did not force them to join separate groups, allowing the shape to dominate.



In grouping objects, colour and shape (‘difference’) dominate closeness.

The grouping of objects on the basis of attributes like colour, size and shape is such a pervasive part of design that we tend to take it for granted in many circumstances. Text is a good example. Letters that are written in the same font and face are easily grouped into words, even if they do not actually spell recognisable words. Changing the attributes of letters makes the words much harder to read, because their component objects become more ‘visible’ than the whole word (Figure 5.13), even though the word boundaries (spaces) are still there.

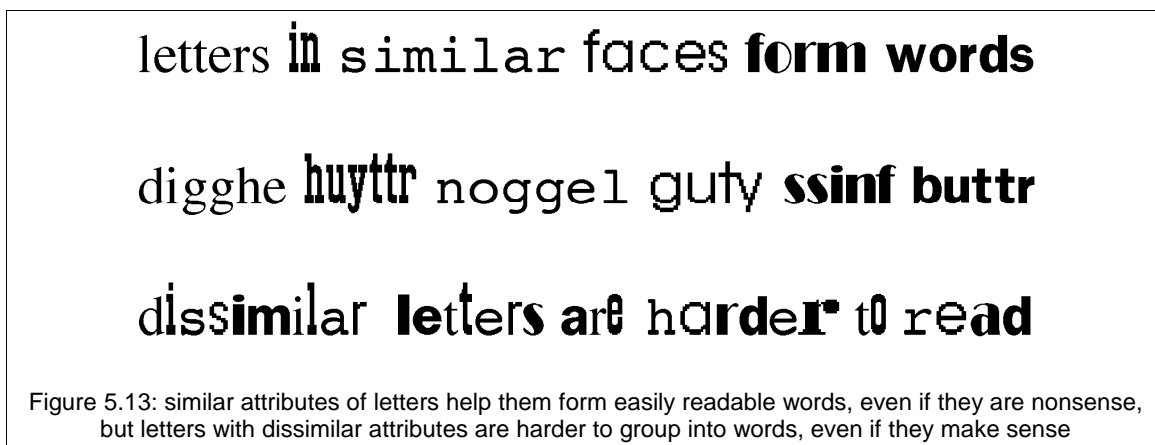

Figure 5.13: similar attributes of letters help them form easily readable words, even if they are nonsense, but letters with dissimilar attributes are harder to group into words, even if they make sense

Exercise Set 6

1. Draw a structure diagram for parts c, d, e and f of Figure 5.11.
2. Identify the pragmatic subject of the main group in each diagram.
3. Which of the subgroups also have pragmatic subjects?
4. According to the answers that you have given for question 3, is it easier to locate the differently shaped oblong in part d, or the differently textured icon in part f?

•6• The user's task

Tasks have structure too

The first displays that we analysed at in this guide required users to operate 'control panels' for lighting and heating (Figure 1.8). The two designs differed in the way the on and off buttons were grouped: as columns of similar buttons, or in rows with the room label. Although we suggested that the 'rows' design was better for a user who had to control rooms individually, someone who had to check that the lights or heating were on or off in the whole building would benefit from the column grouping. This showed that it was necessary to consider the task that the user was performing, because this would affect the order in which they would want to move between the screen objects.

Figure 6.1 uses a structure diagram to show the difference between these two tasks. To 'check a room', the user has to find the room, and then check the buttons. To 'check the building', the user needs to successively check buttons, but doesn't need to look at the room numbers.

Having used the structure diagram to represent these tasks, we could also use the transition path diagram to show the sequence in which the steps of the task are carried out (Figure 6.2). These are particularly simple tasks, and as we have shown them, just require one transition 'down' into the structure of the task before the separate steps are carried out. By explicitly showing the order that those steps are carried out, they do give us the information that we need to choose between the 'row' and 'column' designs of the control panels.

In the first task, the user has to first find a room, and so the display must be structured to support a visual transition from the panel to the room numbers, followed by a transition from the room numbers to the related buttons. In the second task, the user has to locate the set of relevant buttons, and then must be able to make a sequence of transitions through them.

Until now we have emphasised that the structure diagrams and transition path diagrams represent the 'objects' that the user is perceiving on the display, and have linked this to the concept of a mental object representation. Clearly, the steps of a task are not objects, and yet we have shown that they can also be represented by the diagrams.

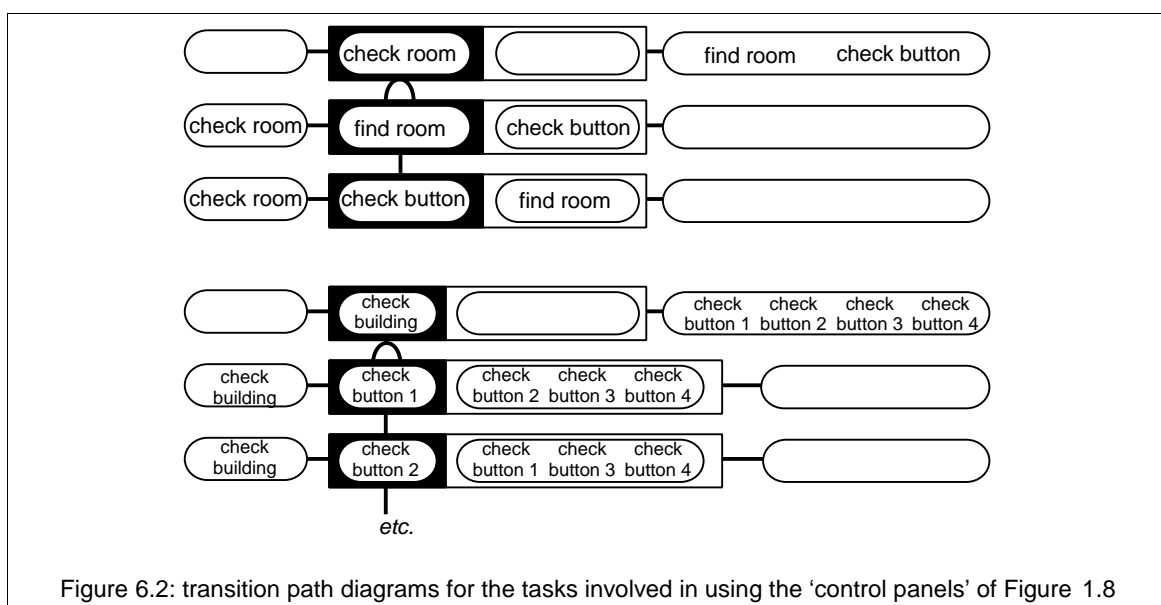
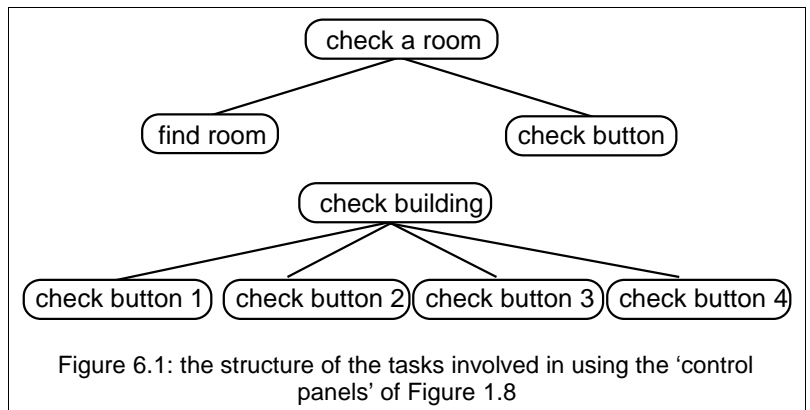

In our discussion of the icon search task, where people had to locate an abstract or representational icon from the arrays shown in Figure 5.1, we explained that a propositional representation of the ‘target’ icon was used to control the search: each icon was compared against it until a match was found. We went on to describe how propositional ‘knowledge’ could affect the perceived object structure, and showed how the use of two different button layouts in a hypertext (Figure 5.4) affected the propositional knowledge that people developed. As you might expect, task structures are also propositional representations. We can use the structure diagrams to represent the breakdown of tasks into steps (and task steps into smaller steps, if necessary) in the same way that objects can be broken down into smaller, component parts.



Task structures are propositional representations, and can be analysed using structure diagrams and transition path diagrams.

This is important in designing displays because of the feedback loop between propositional and object representations, as shown in Figure 2.2. Many of the examples we have shown in the last few sections have indicated that the propositional expectations about a visual figure can affect the object that is actually perceived. These examples were equivalent to single-step tasks, where the propositional representation was just some expected shape. In tasks that have several steps, the subject of the propositional representation will change to represent each step in turn. Just as transitions can be made through an object structure, zooming-in to objects and stepping through their component parts, transitions can also be made through a propositional structure, as the user concentrates on the steps of a task and tries to carry them out in the right order.

The design of the display can help the user make these transitions by providing object representations that match the structure of the task. When the user needs to choose one from several task steps, a display that has the appropriate screen element forming the psychological subject of the user’s object representation will be providing helpful information through the object-to-propositional transformation.



An object representation that matches the task structure can help users form the appropriate propositional representation of the task

This is the reason why the ‘lighting controls’ of Figure 1.8 are better suited for the task of controlling individual rooms, while the ‘heating controls’ are better for controlling the whole building. The rows in the lighting controls support the transition from the room label to the relevant button, while the columns in the heating controls support the transition from button to button, as indicated in Figure 6.2. As the evidence from the use of the hypertext system showed, the way that users will come to think about a task can be influenced by the display structure. Designers of displays can take advantage of this to help users from propositional task structures that will be easy to recall, as the next few examples will show.

Ambiguity in task structures

Imagine someone who uses an ordering system in which they receive requests and have to process them, in a strict order (this system is one that has been used in experiments, but is based on real applications). The requests contain four pieces of information that need to be ‘established’ (e.g., copied into another form) and ‘actioned’ (e.g., sent to another department). The eight steps are:

1. **Display** the *time* the message was received
2. **Stamp** the order with this *time*
3. **Locate** the *originator*’s address
4. **Confirm** receipt of the order to the *originator*
5. **Index** the *register* number of the ordered item
6. **Store** the *register* number on the order form
7. **Identify** the address of the *recipient*
8. **Dispatch** the order to the *recipient*

The bold word in these steps is a command name that the user has to type into the system to perform the operation. Figure 6.3 shows two ways that the user could do this task. In the first structure, the user establishes each piece of information and actions it immediately before going on to the next piece, as in the sequence given above. This produces four ‘pairs’ of task steps, which we have labelled with the piece of information that is being established and actioned in each pair (shown in italics in the sequence above). In the second structure, the user carries out four ‘establish’ operations to get all of the pieces of information from the message (steps 1, 3, 5 and 7 above), and then ‘actions’ them all (steps 2, 4, 6 and 8). Either of these sequences seems plausible, but the system must be designed so that only one is allowed: which one should be chosen?

To answer this, look at the two transition path diagrams that correspond to the use of these structures (Figures 6.4 and 6.5). These show that the ‘two groups of four’ structure requires thirteen transitions overall, while the ‘four pairs’ structure requires seventeen transitions. At first sight it might seem that carrying out all the establish operations first, and then the action operations, is the shortest, and so best solution, because the user doesn’t have to make so many transitions

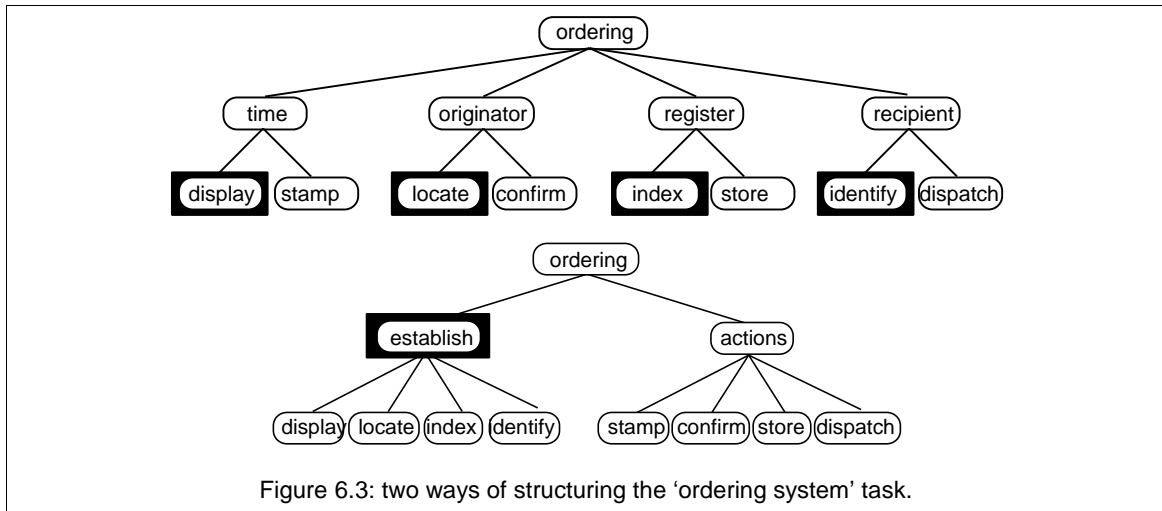

Figure 6.3: two ways of structuring the 'ordering system' task.

up and down the structure. This is not the whole story, though: as with transitions through an object structure, we need to consider how 'difficult' each transition is.

In Figure 6.4, the first transition is from the task overall to the group of 'establish' operations. In Figure 6.3 we have shown this as the pragmatic subject, because you have to establish information before it can be actioned. This means that the transition will be made directly to that part of the task. In other words, it is unambiguous. The next four transitions must be made into and then between the four establish steps (display, locate, index, and identify). There is no pragmatic reason why any of these steps should be performed before any of the others: the user simply has to learn their order.

If the user cannot remember what order these four steps are in, they might make an error. Of course, you might expect them to remember one or more of the steps, but the more options there are, the greater the chance of their making an error by missing one out or choosing the wrong one. For the first transition, there are four steps to choose from, and so in Figure 6.4 we have indicated this by the number 4 to the left of the transition. This is a measure of the 'ambiguity' of the transition. If

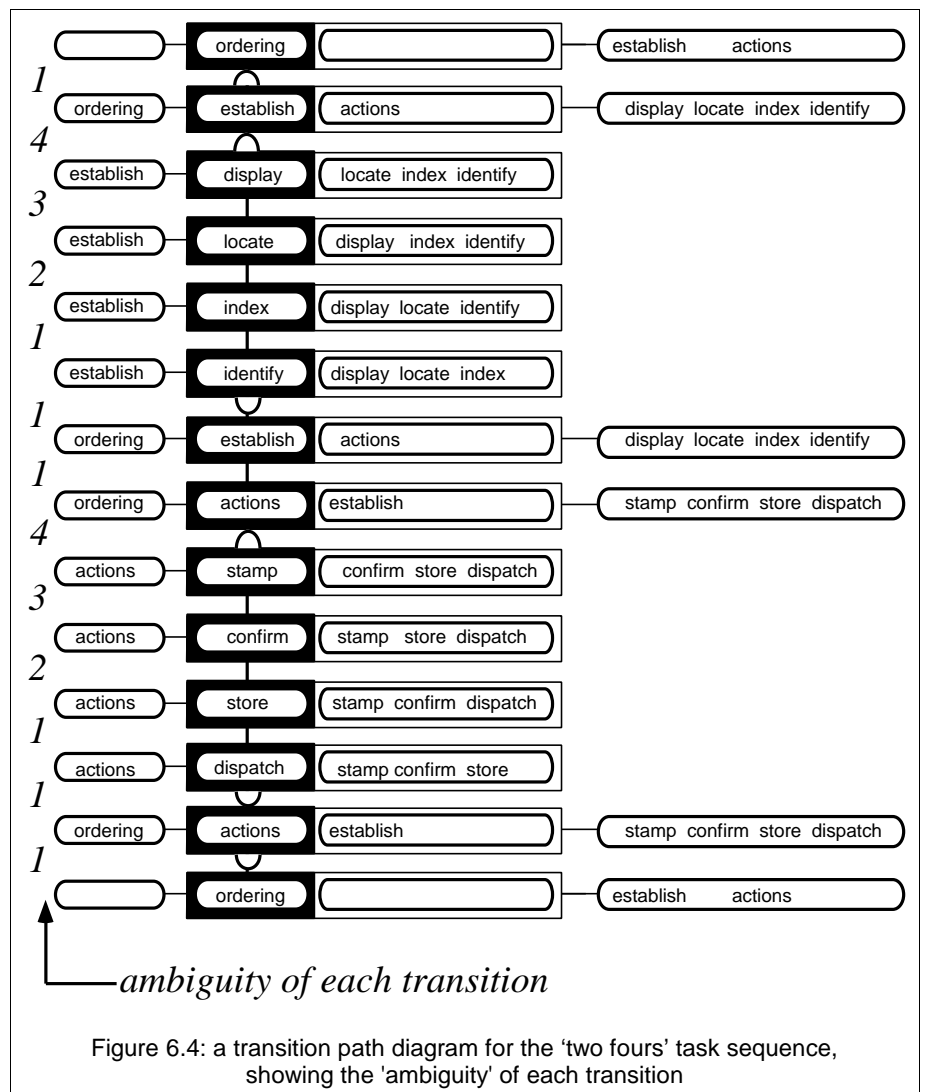
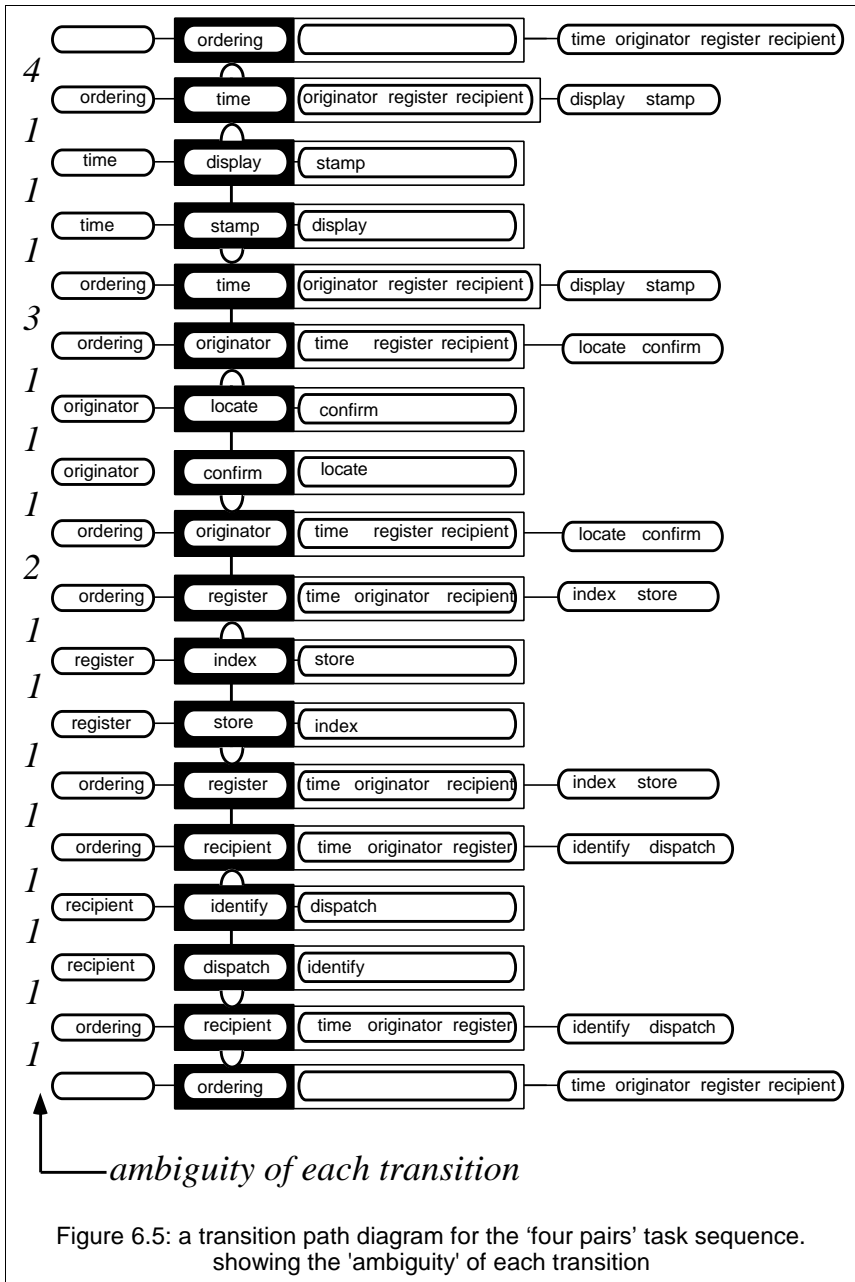

Figure 6.4: a transition path diagram for the 'two fours' task sequence, showing the 'ambiguity' of each transition



they get the first step right, there are then three options to choose from for the second step, and if they get this right, there are then two left for the third step. Of course, if they get the first three steps correct, there is only one option to choose from for the fourth step, and so this step would be unambiguous (i.e., it has an ambiguity of 1).

The next two transitions are back 'up' to the establish group, and 'across' to the actions group. Both of these are unambiguous - in each case there is only one alternative to choose from. Then there are another four transitions through the action steps (stamp, confirm, store and dispatch). Again, there is no pragmatic reason for these to be carried out in the required order, and the 'ambiguity' of each of these transitions is 4, then 3, then 2 and then 1, as for the 'establish' steps. To calculate the 'chance' of a user getting all of these steps right simply by guessing at each transition, we have to multiply all of the ambiguity values together. For Figure 6.4, ignoring the 1s, this is $4 \times 3 \times 2 \times 4 \times 3 \times 2$, which makes 576. This means that if you tried to guess the task sequence for the 'two fours' condition, there are 576 different plausible sequences, only one of which is correct.

Looking at Figure 6.5, we can see that although the 'four pairs' structure results in the same eight steps being carried out, the 'ambiguous' transitions happen at different points in the path through the task sequence. Now the first transition, from the ordering task down to the first pairing, 'time', has an

ambiguity of 4, since there are four pairs to choose from. The next two transitions, through its two steps, are unambiguous, because the 'action' (stamp) cannot be performed until its information has been 'established' (display). There is then a transition back up, which is unambiguous (the steps only belong to the 'time' group) and one across to the next pair, 'originator'. This transition has an ambiguity of 3, since there are three remaining pairs that could be chosen. Again, the transitions through the 'locate' and 'confirm' pair, and then back up to 'originator' are unambiguous. There is now a choice of two remaining pairs, and so the ambiguity of the transition to 'register' is 2, but all of the remaining transitions are unambiguous, including the transition to the final pair, 'recipient', since it is the last one left. This gives a total ambiguity of the path of $4 \times 3 \times 2$, or 24, much less than the 'two fours' path.



The **ambiguity** of a transition is a rough guide to the difficulty users will have in making it correctly

These ambiguity measures are only rough guides to the difficulty that users will have in remembering a path through a sequence, but they do allow different options to be compared by emphasising the amount of support the user will require to 'disambiguate' their choices at each transition. In some cases, choices can be supported by the use of 'pragmatic' knowledge about options, such as the constraint that 'establish' steps must come before 'action' steps. In other cases,

users can be supported by the structure of information on the display. If, instead of simply having to type the eight steps in the ordering task, users could click on buttons, the ordering of the buttons on the display could be used to provide information about the required order of the commands.

In practice, you don't always need to construct the complete transition path diagrams to calculate a task structure's ambiguity. The numbers to be multiplied can be obtained directly from the structure diagrams. We drew the transition path diagrams here to show what the measure really meant in terms of the demands that the interface design was placing on the user's cognition – and they could equally well help in teasing apart difficulties in more complex situations, or in persuading other designers about a problem.

Conceptual structures

An important point to note about propositional representations is that the clustering of task steps into groups can be purely 'conceptual': the middle level in the structures of Figure 6.3 has no command or button-press associated with it. This level simply reflects the way that the users have been taught the task. It is part of their mental model of the task, not part of the real world. All the computer system cares about is receiving the eight commands in the right order.

Because people can learn the structure of tasks, it can be beneficial to give different tasks within a system a common structure. This can reduce ambiguity by removing the need for users to choose between different structures. Imagine a Cash Machine that, once the user's card has been inserted and their secret PIN number verified, allows people to either press a button to accept out a default amount of money (£50), or to press another button to request a specific amount (e.g., £30 or £60). This requires people to learn two task structures, depending on whether they want the default amount or a different amount, as shown in Figure 6.6.

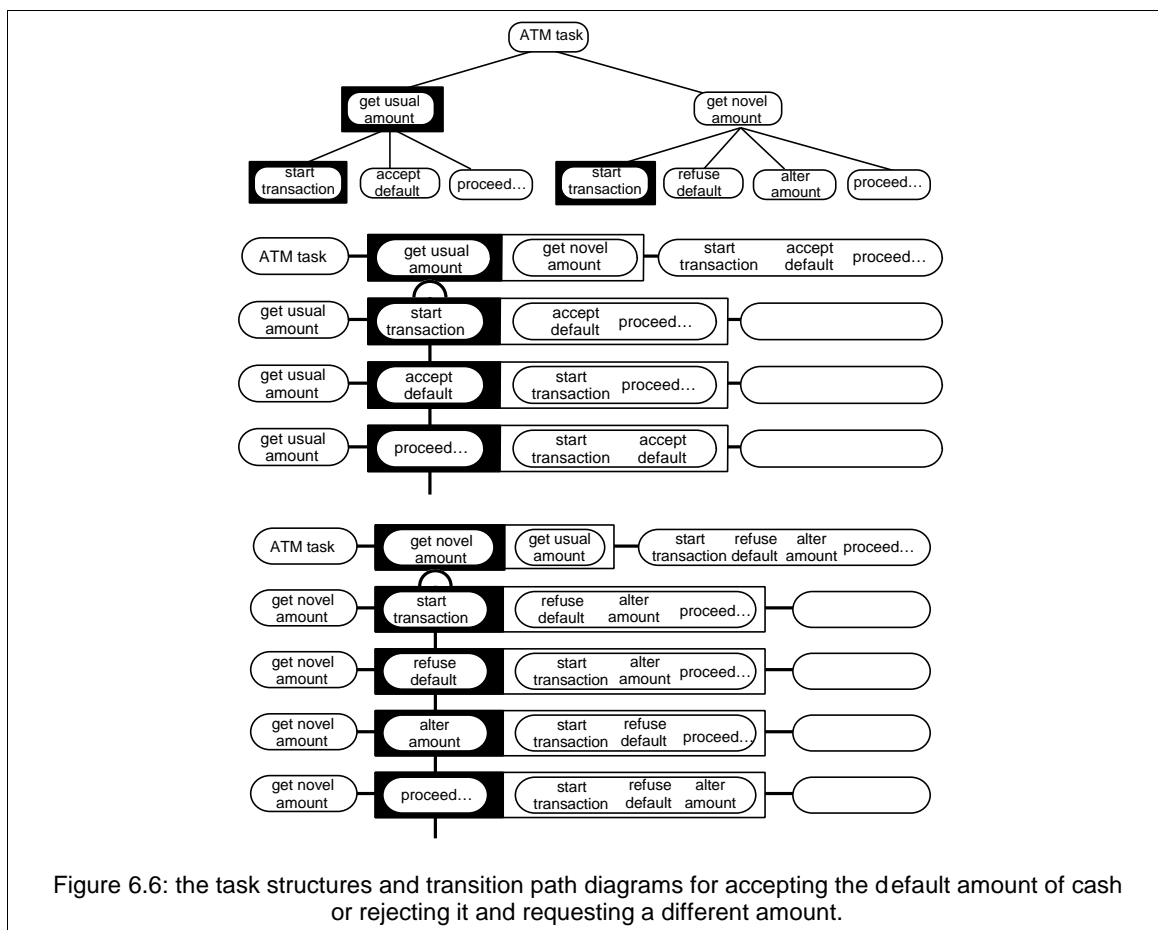

There is no ambiguity in this task structure, since the order of each of the steps is constrained for pragmatic reasons. It differs from the 'ordering' system in that not all of the steps have to be carried out: only one of the two sub-tasks needs to be carried out each time the Cash Machine is used. This is fine for users who want to 'get usual amount', since as it is the most frequent action that perform with the machine, it will be the pragmatic subject. On the occasions that they don't want £50, though, they will have to remember to carry out a different set of steps, but one that is not immediately different. In

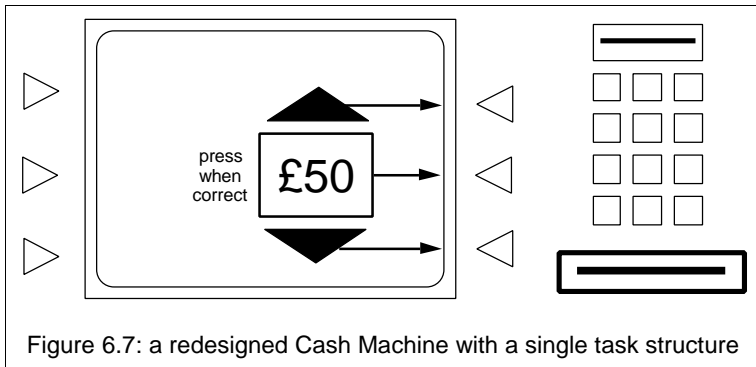

Figure 6.7: a redesigned Cash Machine with a single task structure

fact, once they have gone through the ‘start transaction’ step, they may simply carry on with the rest of the most frequent sequence, and ‘accept default’, even though it isn’t what they wanted.

Suppose the machine were redesigned, so that instead of pressing one button to accept the default, and another to go on to a different dialogue where they could specify a different amount, both tasks were merged into one. In the machine shown in Figure 6.7, the user can press the middle button to get the amount shown, or they can press the upper or lower buttons to

increase or decrease the amount shown, and then press the middle button.

This combines the task structures for taking default and novel amounts into one structure, as shown in Figure 6.8. Users always have to start the transaction (i.e., insert their card and PIN number) and then ‘operate on default’ before proceeding to take their card, receipt and cash. The task is no more complicated on the occasions that people want the default amount shown, but the transitions through the task structure now require them to make a visual transition to the amount, whether they want the default or not. Once they have done this, they are more likely to ‘notice’ whether it is the amount that they want, and so will be less likely to slip into accepting it when it is not.

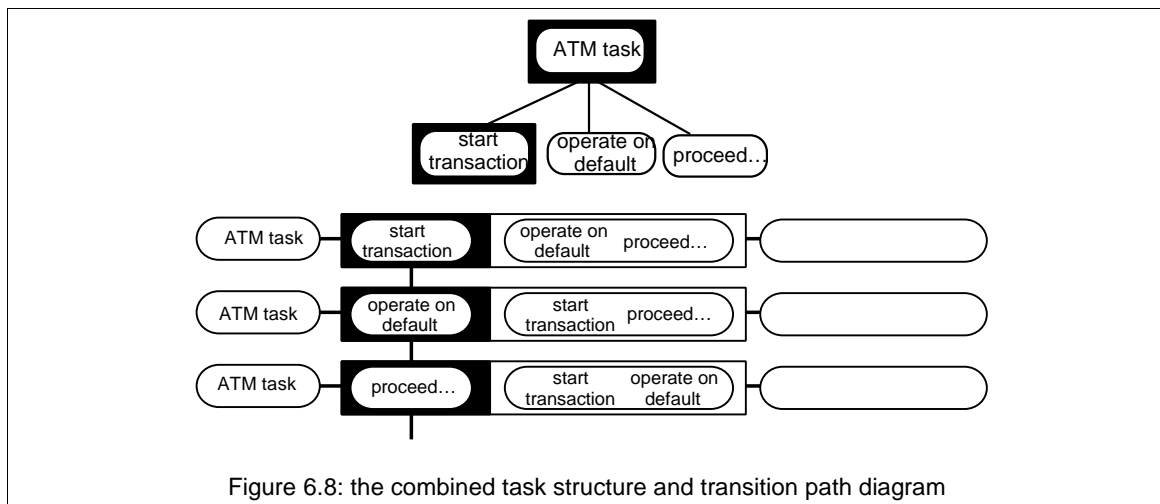

Figure 6.8: the combined task structure and transition path diagram

Complex multiwindow displays

The displays we have looked at in the examples so far have been comparatively simple, with only a few objects or groups of objects on the screen at a time. Many displays are, of course, more complex than this, particularly those with several different windows, which can be rearranged or resized by the user. Letting the user position groups of objects on the display clearly reduces the designer’s ability to control the structure, but the techniques that we have presented can still provide some support. In particular, the contents of different windows can be compared with the tasks that the user will be carrying out, to ensure that they can easily move from window to window without having to laboriously search for the information that they want.

The interface shown in Figure 6.9 is a system that lets travellers make enquiries about internal flights in America. Travellers can use a mouse and keyboard to enter information, and can also input speech by holding down a button (The microphone icon in the ‘Record’ window). The translated speech input is shown in the ‘Recognition’ window. The multimedia aspects of this interface are not at issue here. We are going to consider the visual structure of the interface and think how this might affect the user’s tasks.

Figure 6.10 shows the first level of a structural diagram for this screen. Because all of the windows can be moved around, resized, and repositioned by the user, we can’t really tell anything about the groupings that they might form in practice (in Figure 6.9, for example, there is a cluster at the upper right, a cluster in the centre, and a group along the bottom of the

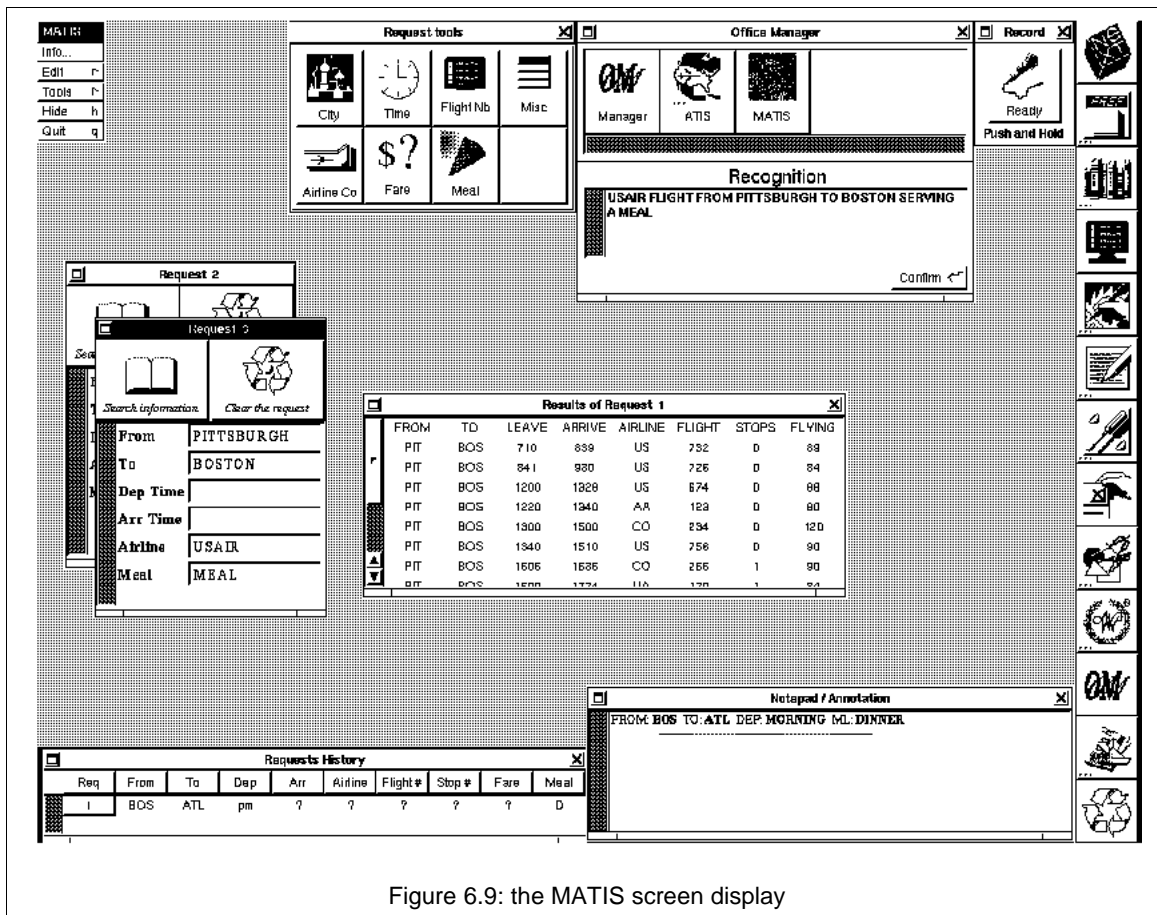

Figure 6.9: the MATIS screen display

screen). The arrangement of the windows within the screen has been maintained in the structure diagram, to help you identify the screen objects that they refer to. This can be a useful technique for complicated displays, but it only really works for showing one level of a single object's structure at a time.

If we just look for now at the requests, which are on the left of the screen, we can produce a structure diagram of one of them (Figure 6.11). In this diagram we have included several levels of structure, and so have not been able to maintain the spatial organisation of the objects, as we could in Figure 6.10. We have been able to indicate which object within each level, if any, forms a pragmatic subject.

The window consists of the heading (which contains the name of the request and a close box), the icons (one to start a search, the other to clear the form), and the request form itself. This has a scrollbar and a list of search criteria, that each have a title and a slot, which will all be empty when a new request is created, but which will be filled in by the user. In this Figure we've just shown the structure of the 'From' and 'Arr Time' slots, but the others have similar structures.

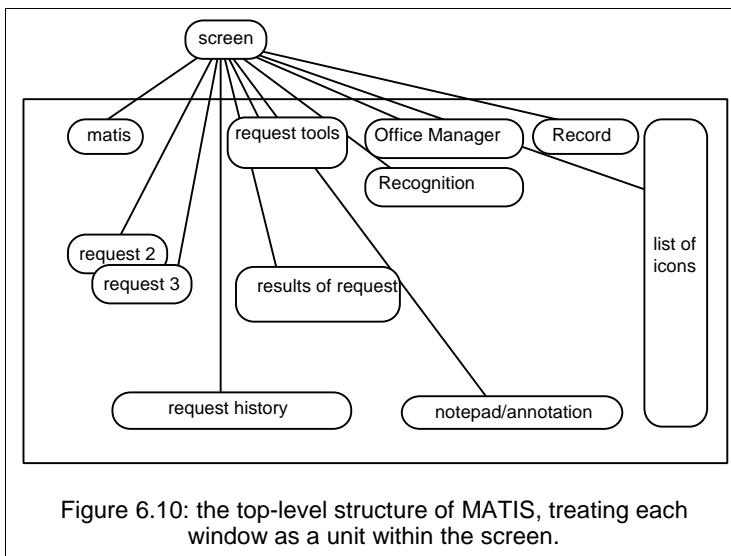

Figure 6.10: the top-level structure of MATIS, treating each window as a unit within the screen.

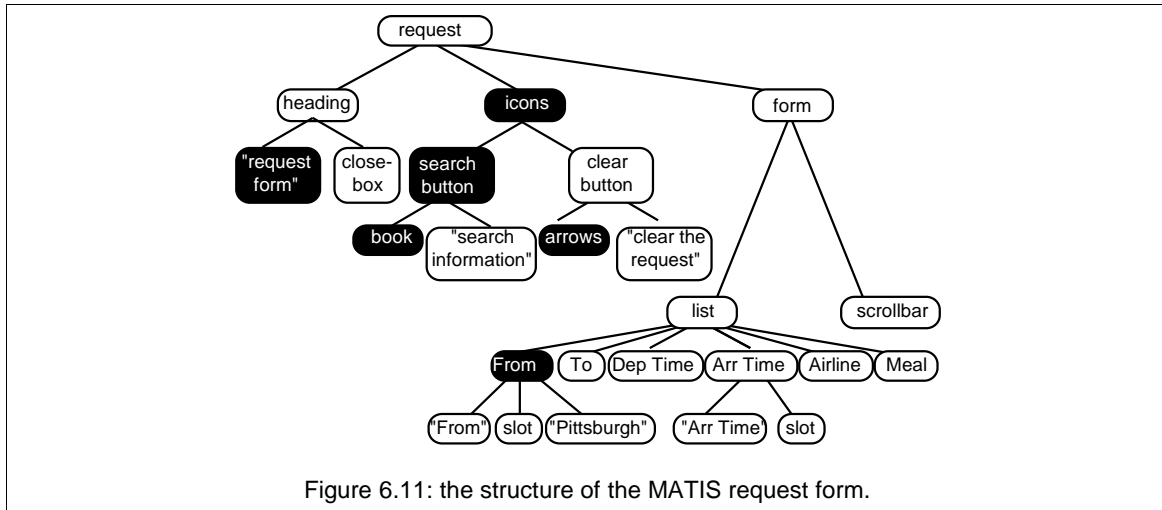

Figure 6.11: the structure of the MATIS request form.

What can you tell about the use of this structure? To begin with, the icons are likely to form the pragmatic subject of the form's structure, since as a group they pop out from the textual content of the rest of the objects. This is good, because in searching for this particular form, this group discriminates it from all other windows within the display – none of them contain this group or the two objects it is composed of. The user will be able to form the mental image of, say, 'a book', and will be able to reject any other windows as soon as they look at them.

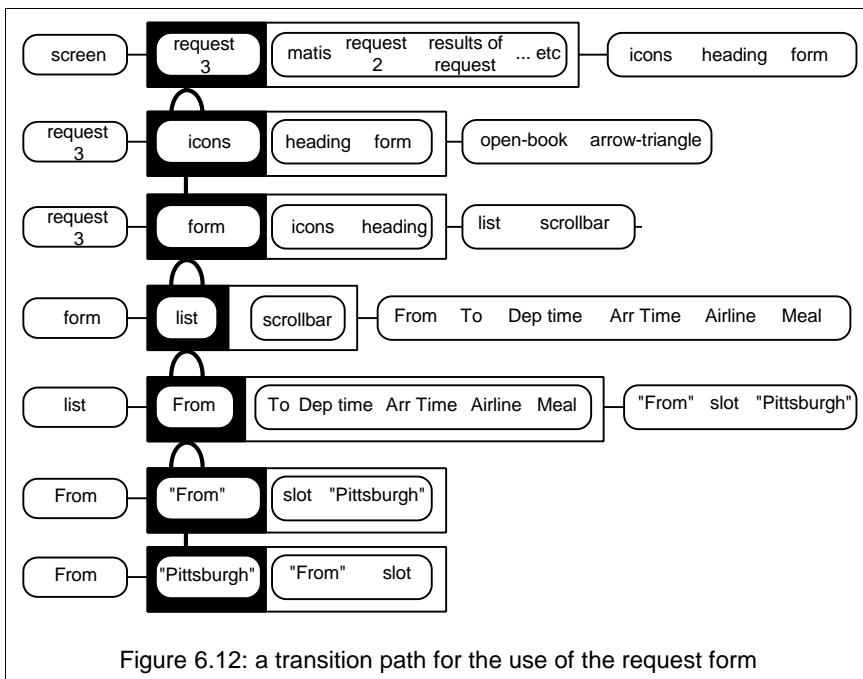

Figure 6.12: a transition path for the use of the request form

Once they have found this window, they will probably want to find the slot that they have to enter a specific piece of information in. Most requests will be to find a flight from one city to another. These two slots are the ones that are most likely to be filled first on a form. The names of these two slots appear at the top of the list on the left of the window, and since people usually read from left to right and from the top of a column down, we can suggest that the 'From' slot will be the pragmatic subject of this group, and so the easiest one to find – consistent with the users' most frequent task.

The 'granularity' that you need to use to describe a structure depends upon the way that people will have to use it. As we have seen with icons, the structure of objects might need to be

considered if they have to be discriminated from one another, but it may be sufficient to describe, for example, three lines just as 'lines' without further decomposing them into 'line + line + line'. In Figure 6.11, you'll see that we haven't decomposed words into their constituent letters, nor the 'book' and 'arrows' icons into their structures, since in both cases the pragmatic subject of each of them would be sufficient to discriminate it from the other objects within its group. If you didn't know what these icons meant, though, and were searching for a textual label that meant 'start a search', you might have difficulty locating it, since it is part of the predicate of an icon, whose pragmatic subject (a book) is not usually associated with the task of searching.

Figure 6.12 shows a transition path that a user might make to fill in a request form (that is already open), to enter the information about the city they want to fly from. We can tell from the structural description that people need to read down the list of slot-names, and then make a transition to the slot. One thing that might make it easier for this last transition to be made is if the slot names were right justified, rather than left justified, but this in turn might break up the visual structure of the list, and make the name harder to find in the first place.

Looking at the items within the list, you can also see that in an empty form, they all have the same structure. As soon as they get filled, their structure becomes more complex - an additional part is added. As with the 'circles' and 'circles plus gaps', the filled slots stand out from the empty slots, and so are more noticeable.

Exercise Set 7

- 1 Draw structure diagrams for the 'Request Tools' and 'Results of request' windows shown in Figure 6.9 – but don't go into too much detail.
- 2 Complete the structure diagram of the Requests window by adding the contents of each filled and empty slot.
- 3 Suppose the user had just entered 'Pittsburgh' into the 'from' slot of the Request form, and 'Boston' into the 'to' slot, so that they are now looking at the word 'Boston' (and the rest of the slots are empty). Draw a transition path diagram to show how they would:
 - a) locate the search button to carry out the request
 - b) find a flight that departs before midday from the 'results of request' window (which will be the one shown in Figure 6.9).
- 4 Consider the task steps the user will be making at each moment in this transition path diagram (that is, before making each transition), and so what propositional representation will be guiding their search. At one point the object representation provided by the display does not correspond to the propositional representation. Can you spot a simple change that you would recommend to improve this display?
5. Suppose all of the slots had been filled in – does this change the way the 'list' object is structured? Draw a new structure diagram for the 'list' object.

•7• Multimedia Perception

Most of this guide deals with the design and layout of objects on the display, since this is by far the commonest form of computer interface. As you have seen from the previous section on tasks, the same structural analysis and diagrams that we introduced for object representations can be used to look at the propositional level of representation. This is because of the assumption in our psychological framework, ICS, that each of the nine cognitive subsystems operates in a similar fashion, even though the information they each process is different in nature. This also means that the blending of propositional and visual inputs at the object subsystem can be used as a guide to help us understand blending of other levels of representation, opening up the way to an analysis of multimedia interfaces.

Relationships between levels

We have used structure diagrams to show how the focus of attention can move between different objects, and transition path diagrams to show how the structure of the object representation changes over time as attention moves. Objects that had been part of the psychological subject's constituent structure could be focused on, in which case the whole representation shifted down a level in the structure. Conversely, the representation could shift up a level if the group was made the new subject.

A similar change happens as representations are transformed between the different subsystems in ICS, although this does not correspond to a change in attention, since it is happening continuously, and in parallel. Each time a sensory representation (acoustic or visual) is transformed to a perceptual representation (morphonolexical or object), the psychological subject moves up a level - so whatever was the group in the sensory representation becomes the subject of the perceptual representation, and the subject and predicate become its constituent structure. The constituent structure of the sensory representation is lost in this transformation - which is why as representations are transformed in this way, they become more abstract, and contain less sensory detail.



Transformations from sensory to perceptual levels **move up** a level in the structure of the information

Figure 7.1 illustrates this process happening as a fragment of speech is comprehended. The sound of the word “shy” is composed, at the acoustic level, of a subject (“the sound of the phoneme “sh”) and a predicate (the sound of the phoneme “eye”). Each of these phonemes have a constituent structure made up of patterns of sound energy that are called “formants”.

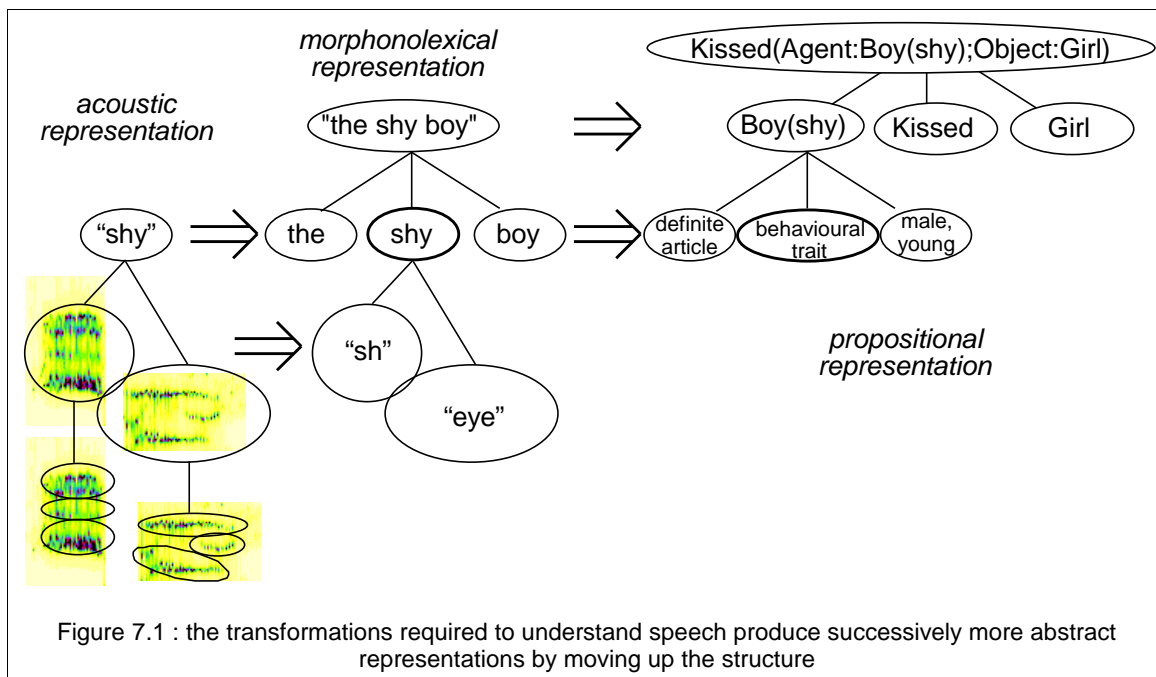

Figure 7.1 : the transformations required to understand speech produce successively more abstract representations by moving up the structure

When the acoustic-to-morphonolexical transformation operates on this representation, the formants are discarded, and the subject of the new representation becomes the whole word, “shy”. Its constituent structure is now made up of the subject-

predicate level of the acoustic representation, although because this is a different level of representation, the nature of the information has changed. The transformation has also added a group to the structure, binding the word “shy” in with the rest of the speech that has been heard - for convenience, we have shown here the next word that will be heard, as well.

A similar process occurs when representations are transformed by the object and morphonolexical subsystems into propositional representations, and then by the propositional-to-implicational transformation. All of these transformations make the group of the incoming representation the subject of the output representation. In Figure 7.1, the phrase “the shy boy” becomes a single ‘fact’ in the overall propositional representation of a sentence. The individual parts of speech now form the constituent structure. A further transformation would produce an implicational representation that would have the ‘scene’ of a shy boy kissing a girl as its subject, and the group that would be added might be something like “embarrassing situation”, allowing propositional predictions to be made about what the girl might do next.

As you might expect, transformations from implicational to propositional, then to object and morphonolexical, and then to articulatory and limb representations all have the opposite effect on the structure. These make less abstract representations by discarding the group, making the subject the group, part of the constituent structure the subject, and adding a new level of information as its constituent structure.



Transformations from central to perceptual levels **move down** the structure of the information

You can imagine a similar sequence of transformations as those shown in Figure 7.1 happening for the production of speech. A propositional representation that had a phrase or a clause as its subject would be used by the propositional-to-morphonolexical transformation to produce a structure that had the individual words as its subject and predicate. This transformation would have to add the new constituent structure of these units, so adding in an image of the sound of the overall word - which is the speech that we can ‘hear in our mind’ when we try to plan what to say. This representation would then be used by the morphonolexical-to-articulatory transformation to produce a representation of each of the sounds in the words. Unlike Figure 7.1, of course, this would represent the intended sounds, rather than the sensory sound of the acoustic level, and it would control the muscles used in speaking.

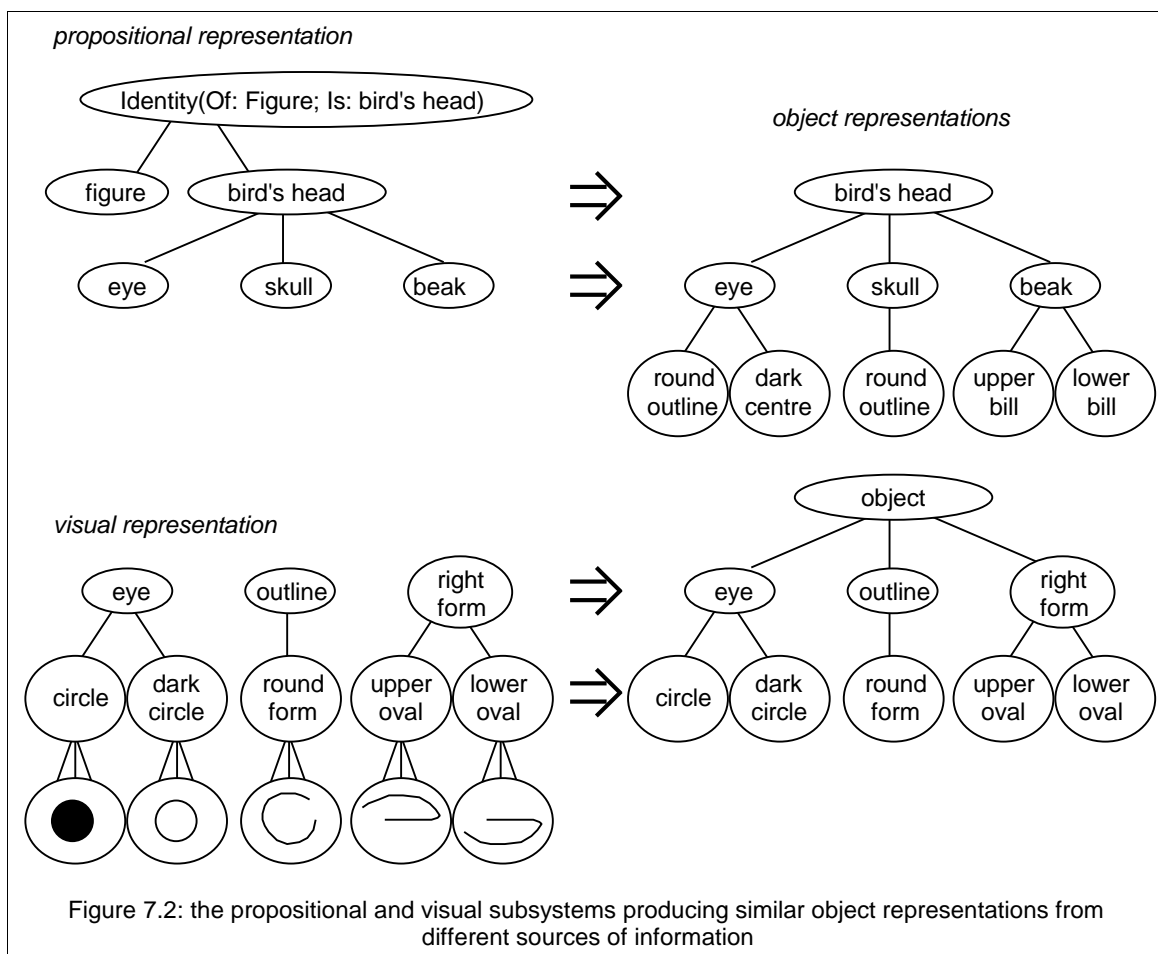

In summary, there is a sequence of abstraction as information is received and interpreted by the cognitive subsystems, and a complementary sequence of elaboration as feelings produce ideas, which are used to form mental images, which control behaviour. This sequence provides us with a key to understanding the blending of different sources of information into a single representation, because although the representations at each source will necessarily contain different types of information, the group at one level can correspond to the constituent level at another.

Figure 7.2 illustrates what might happen if you have just read that “Figure 2.4 is a bird’s head”. The constituent elements of the propositional representation include ideas about the structure of a bird’s head. When you look at the figure, your visual representation identifies where all of the lines and circles are and groups them into possible objects to make an object representation. At this point the object representation that the visual subsystem has produced is rich in visual description, but only one of the features, the eye, is identifiable. In contrast, the propositional subsystem has produced a vague description of a bird’s head, but is lacking visual detail.

We have used this example because the structure of both object representations is very similar, and, in particular, the subject is identical. The similarity in structures means that the visual objects picked out by the visual subsystem can each be matched with a corresponding label provided by the propositional subsystem, so that the resulting blended object representation is much richer than either individual input.



Representations from different sources can blend if their structures are **consistent**

This example used information from a single sensory modality, which was being blended with an existing propositional idea, but the same process underlies the blending of sound and vision. The possibilities are more complex, however, because blending could potentially occur at any of the four perceptual or central subsystems. In fact, blending could be occurring at any of them simultaneously.

Blending sight and sound

The examples we have been discussing so far have all dealt with blending of object representations. Figure 7.3 shows the most direct routes by which acoustic and visual information can reach the object subsystem. Notice that while the visual sensations can be transformed directly into object representations (by the visual-to-object transformation), there is no corresponding acoustic-to-object transformation.

The sounds must first be structurally interpreted as morphonolexical representations, and then identified propositionally, before the propositional-to-object transformation can produce representations at the appropriate level. Similarly, the implicational representations of the general meaning of sights and sounds cannot affect the object level of representation directly, for there is no implicational-to-object transformation. These too must be propositionally interpreted first (this is not shown in the figure).



Sound cannot directly produce mental visual images

The consequence of this is that the object subsystem does not receive direct inputs of multimodal origin, and that our perception of the visual world is not directly affected by the sounds we hear. However, as Figure 7.4 shows, there can be effects of our visual perception upon the way we interpret sound.

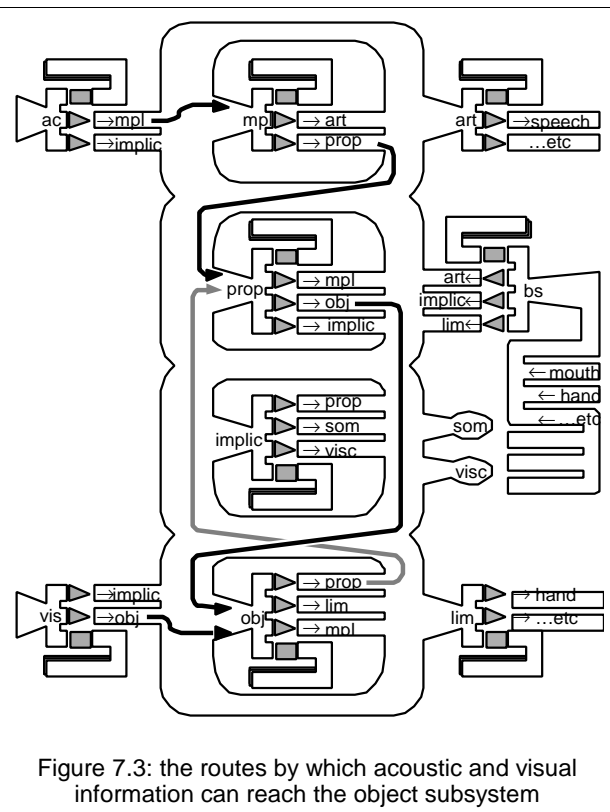

Figure 7.3: the routes by which acoustic and visual information can reach the object subsystem

Like the object subsystem, the morphonolexical subsystem receives representations from the propositional subsystem and from its sensory partner (the acoustic subsystem), but it also receives input from the object subsystem. This asymmetry in the communication between the perceptual subsystems

is most apparent when we read, since we can form mental images of the sound of a speaker’s voice as we see words, in parallel with our comprehension of the text’s propositional meaning.

Usually, the fact that two transformations are necessary to turn visual sensations into morphonolexical representations, while acoustic sensations only require one, means that the resulting morphonolexical structures are not ‘coherent’. They do not match as well as those illustrated in Figure 7.2, and so blending does not take place. However, lip movements are a special case, because their visual structure is very closely related to the acoustic structure. Despite the additional transformation, it seems that a speaker’s lip movements are usually blended with their speech - which is why ‘out of synch’ films are so difficult to watch.

A strange consequence of this blending of sight and sound occurs in the ‘McGurk effect’, where the sound of a speaker saying “ba ba ba” is dubbed onto the lip movements of them saying “ga ga ga”. Most people actually report hearing the sound “da da da”. Furthermore, even when you ‘know’ about this effect, and so have a propositional representation of what the speaker is actually saying, the effect still occurs, showing that there must be a direct link between the object and morphonolexical subsystems that does not go through the propositional level.

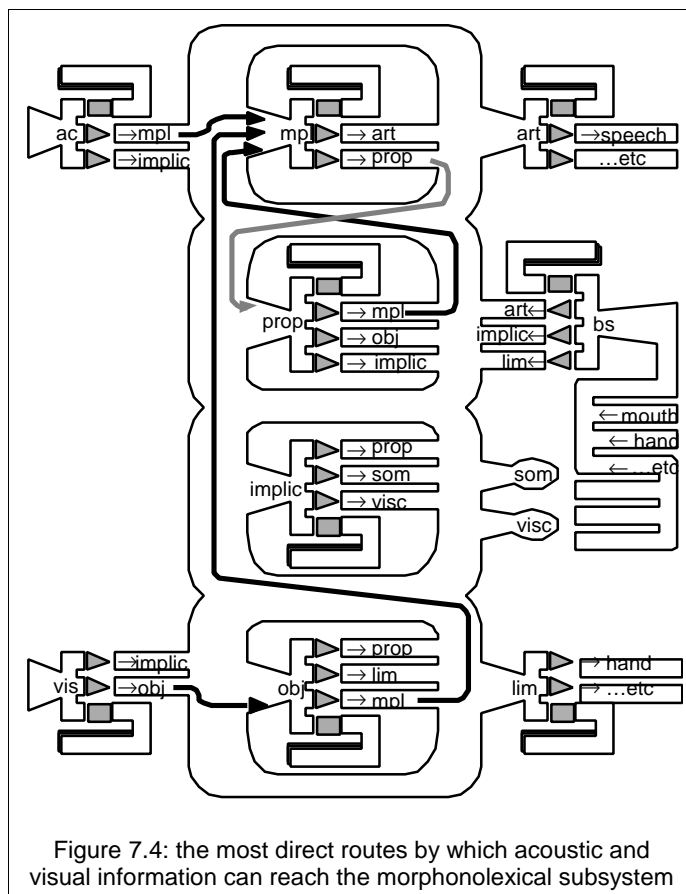

Figure 7.4: the most direct routes by which acoustic and visual information can reach the morphonolexical subsystem



Visual perception can affect the way we interpret sound.

As computer interfaces become more and more advanced, the relationship of sight and sound is becoming more and more important. At first, it seems as if there will be a big problem in synchronising voice with video clips, or in videophone conversations, or in the use of animated ‘speaking’ characters. In practice, it seems that for blending of sight and sound to occur, there must be very accurate visual information, or the object-to-morphonolexical transformation is not able to produce a clear enough representation. The McGurk effect fails when the film of the lip movements becomes small, or is not clearly lit, or is slightly out of synchronisation with the dubbed sound. Paradoxically, here a lack of synchronisation helps people hear what is actually being said, and the same is likely to happen in multimodal interfaces.

While video-windows on computer screens remain small, the quality of the visual information they provide may simply be inadequate to support the normal domination of sight over sound. Difficulties will only occur if the size of the pictures increases, or their resolution improves, in which case synchronisation of sound will become more important (but there may be a compensation in that the quality of the sound will become less crucial, because of the help of the object level).

Propositional Blending

Even when sight and sound can not be quite as directly related as in the McGurk effect, it can be possible to attribute a sound to an object on the screen, using propositional knowledge. Our perception of thunder and lightning being related to the same environmental effect is really due to a propositional understanding, in which the products of the morphonolexical and object subsystems are combined. Young children may be frightened more by the noisy thunder than by the flash of light that preceded it, because they have not learnt that they are both effects of the same event. As we learn this fact, we cease to be ‘scared’ of the thunder, propositionally, even if we are ‘startled’ by it, implicationally.

In the same way, speech can be attributed to a non-human part of a computer interface, provided that the combined propositional representation of the speaking interface object remains within the bounds of implicational models of what is

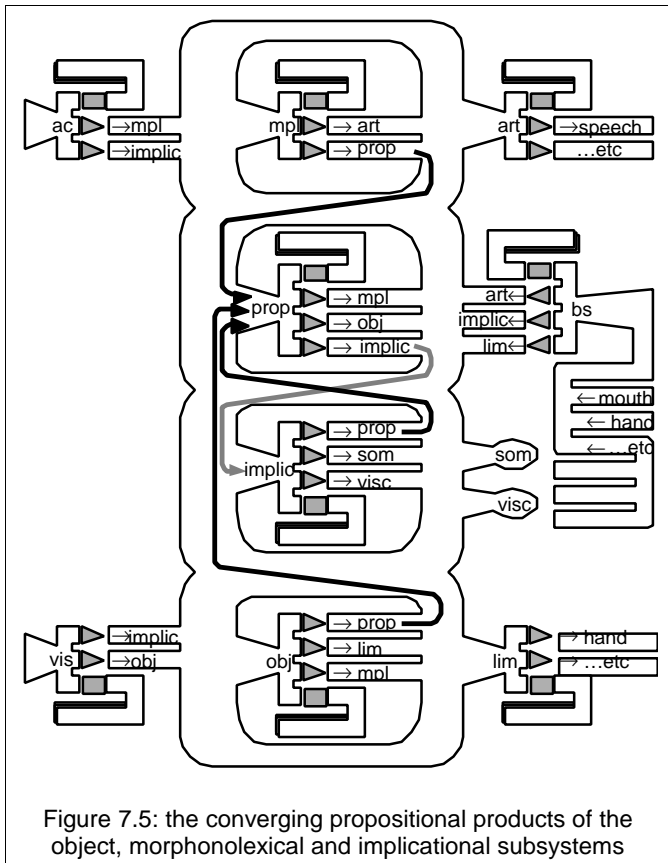

reasonable. It is perfectly acceptable to understand a cartoon tree as speaking to you, but it would take very special circumstances for you to feel comfortable speaking to a real tree.



Implicational knowledge ensures that propositional blending is 'sensible'.

Figure 7.5 details the sources of representations that arrive at the propositional subsystem. As well as the perceptual contributions from the morphonolexical and object subsystems, this figure shows representations arriving from the implicational subsystem. These are largely the result of the loop of reciprocal processing between the propositional and implicational levels, and so serve to keep our propositional understanding of the world stable from moment to moment, so that we generally do not flip between contradictory interpretations of the perceptual data, nor are we prone to accept bizarre interpretations. This feedback loop ensures that, for the most part, we our experiences of the world fit with our expectations. The propositional subsystem is closely involved in our use of language, since it produces the morphonolexical representations that are our 'mental voice', and is where the referential meaning of sound is assimilated. Normally, when people talk, they also make all sorts of gestures. This habit is so ingrained that people will even continue to gesture when they can't be seen, such as when using the phone.

The origin of these gestures lie in our use of external references when we point to things in the real world and say 'that tree' or 'this rock'. The combination of pointing with verbal utterances is called 'deixis', and as we become highly practiced in our use of language, we are also able to use it to 'point' to things that are not really visibly identifiable, such as 'that direction', 'this big', and 'this shape'. These sorts of gestures are a vital part of our communication – try to imagine how difficult it would be to describe things without ever using gesture – and they show the ready blending of propositional representations derived from the morphonolexical interpretation of speech, and the object interpretation of gestures.



Language is comprehended through **propositional blending**.

With the development of speech recognition technology, computer systems that attempt to make use of deixis are becoming available. The MATIS system described in the previous section is an example, for it allows the user to fill in a field of their query form by saying 'this city' while pointing the mouse at a city name displayed elsewhere on the screen, as indicated in Figure 7.6.

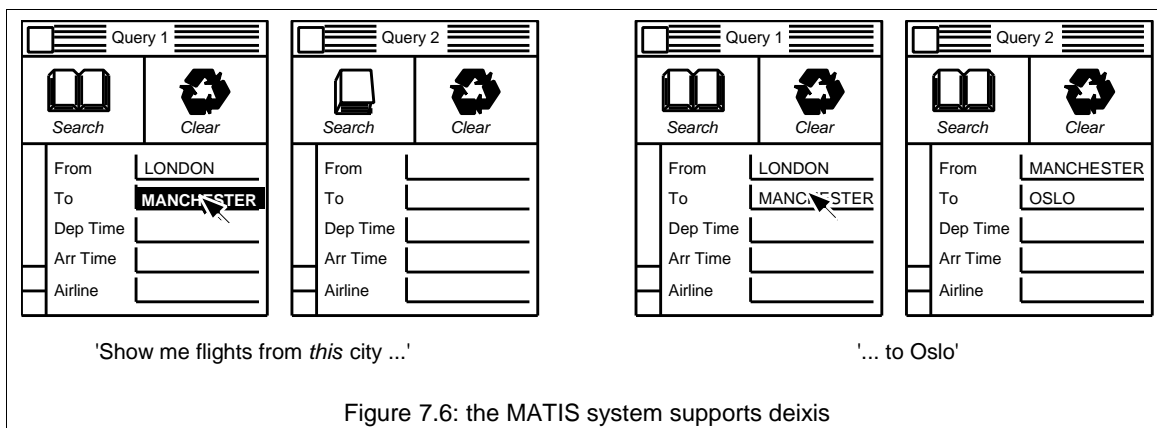

These systems are interesting to consider for a number of reasons. For one thing, pointing with a mouse is quite different to the normal sort of gestures that we use when speaking, and so despite the apparent similarity of the concept, this sort of deixis would take some practice to be able to use naturally. At the moment speech recognition systems take a significant amount of time to identify a word and to provide feedback to the user what it has understood, and even when ‘trained’ on the target words, also have significant rates of misidentification. The delays may well be crucial in preventing their users from being able to make propositional blends of their speech and the results that they see on the screen.

Even if the delays can be avoided by better and faster systems, an analysis of the cognitive processes required for to use this sort of deixis raises a problem. To point to a city name, users have to locate the text on the screen. Just like the user who is searching for an icon, this means that they have use propositional knowledge to form a target of the representation, but this time the target is a word rather than a shape, and so the incoming visual information must be compared with the target at the morphonolexical subsystem, rather than at the object subsystem (or else the user would find themselves searching for the word in a particular font). However, the morphonolexical subsystem also controls the explicit production of speech, via the articulatory level, so once the propositional-to-morphonolexical transformation has produced the target word, they could proceed to speak it straight away, without waiting to locate it, or to move the mouse to it.

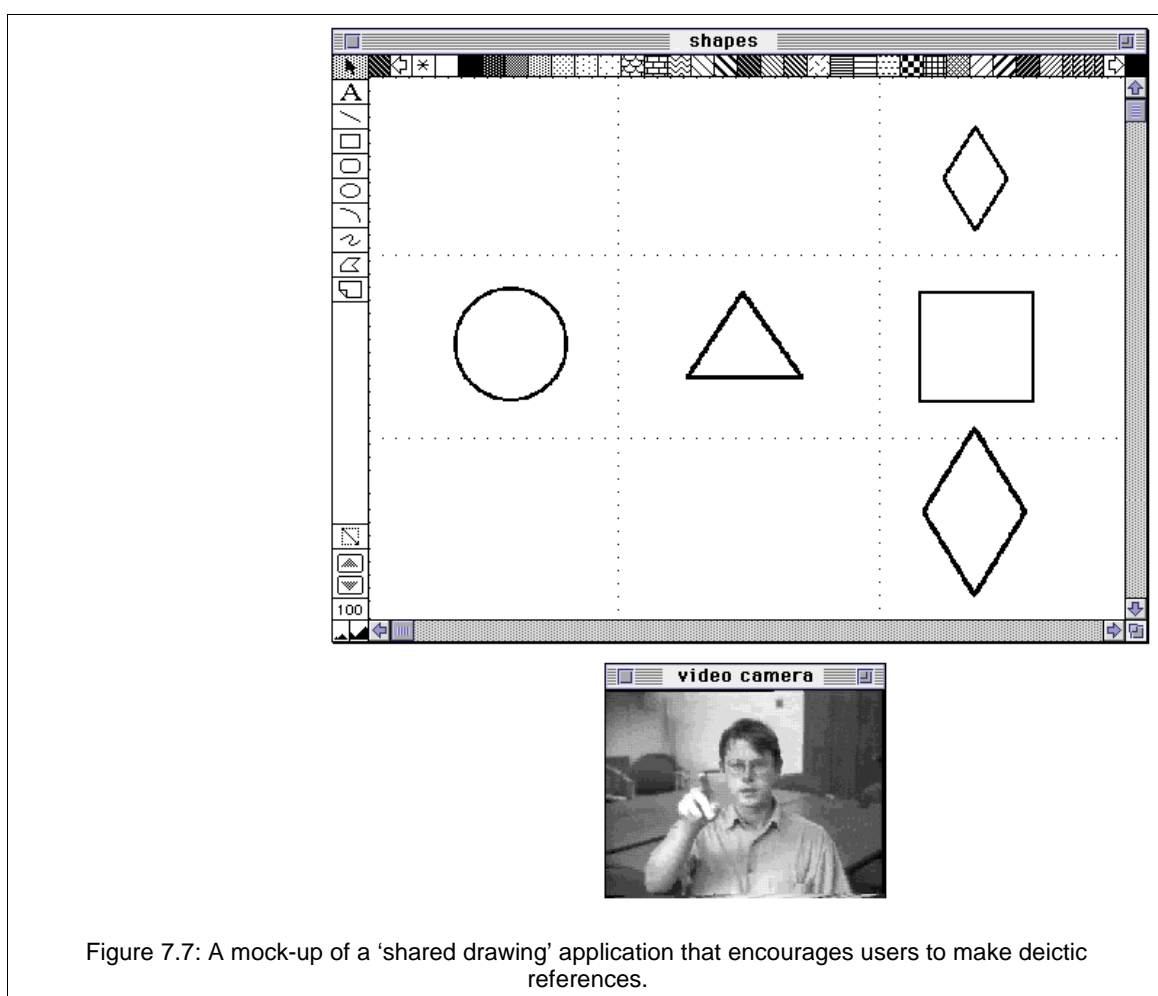

Figure 7.7: A mock-up of a ‘shared drawing’ application that encourages users to make deictic references.

With advanced videoconferencing facilities, pointing and gesturing may have much less precision than that normally attained even with a mouse. Figure 7.7 shows a graphical workspace that is shared between this screen and another user’s, combined with a video window of the other user. Because each user can see the workspace and the other user, as they can in normal situations, they may be encouraged to use deictic reference – in fact, in these ‘computer supported co-operative work’ systems, the use of video-presence is supposed to enhance communication in just this way. However, when this user points at a shape and says ‘move this to here’, it is not at all clear what he wants you to do, because the inadequate object representation cannot be used to derive a propositional representation of sufficient detail.

Implicational Blending

As well as intentional gestures such as pointing, people also make smaller, suggestive gestures that emphasise or otherwise colour their speech, without really being deictic in the sense of indicating a referent. These gestures cannot be said to be influencing the propositional meaning of our speech by their structural, object level interpretation. It is more likely that they are understood by the transformation of the sensory representation into implicational representations, followed by an implicational-to-propositional transformation. In the same way, facial expression can indicate the mood of the speaker, and provide clues about a listener's reactions to what you are saying.

Figure 7.8 shows the routes by which representations can reach the implicational level, which controls such attributions of qualitative meaning. Again, this figure includes the reciprocal loop between implicational and propositional levels of meaning. As we have already mentioned in Section 2, the general contextual sense that the implicational-to-propositional transformation provides can affect our interpretation of events, turning a 'beep' from a helpful informative act by an interface into an annoying and frustrating one, according to the user's mood.

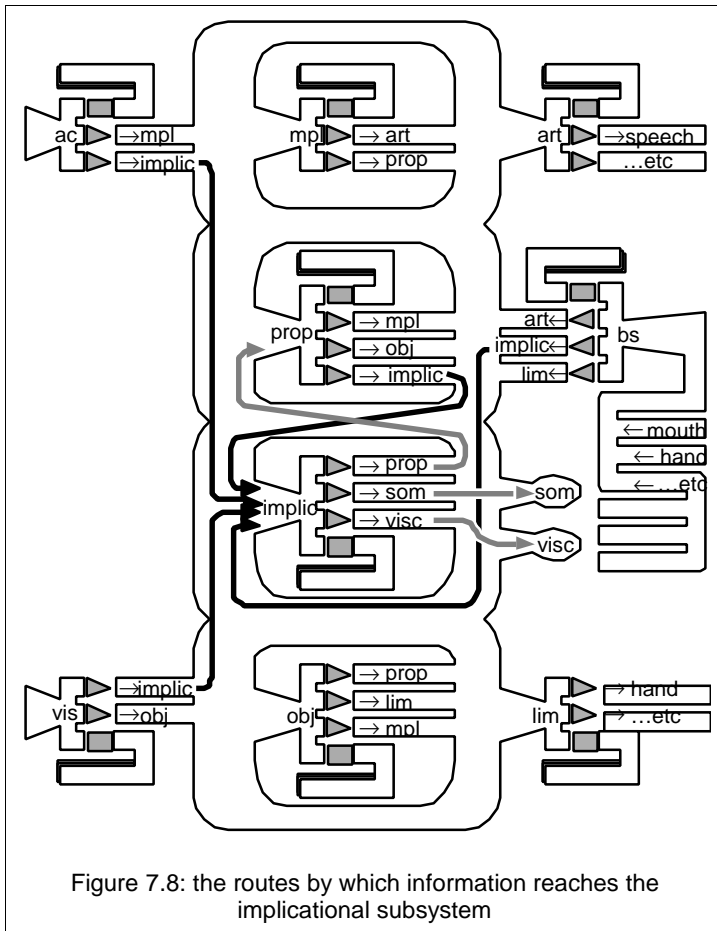

Figure 7.8: the routes by which information reaches the implicational subsystem



Qualitative aspects of sound and sight are detected through **implicational blending**

The direct transformation of properties of acoustic and visual representations into implicational representations allows this subsystem to pick up contextual information from the environment in subtle ways which are often hard to identify, and are attributed to 'feel' or 'style'. As an example, look at the shapes in Figure 7.9.

When asked 'which shape is Takete and which is Uloomo', most people point to the form composed of round elements as Uloomo, and the angular form as Takete. The shapes appear to 'fit' this way around, and not the other – Takete 'sounds' sharp and pointy, while Uloomo 'sounds' round and comfortable. The very difficulty people have in justifying their assessments is characteristic of the involvement of implicational representations, set apart as they are from verbalisation without the mediation of the propositional level.

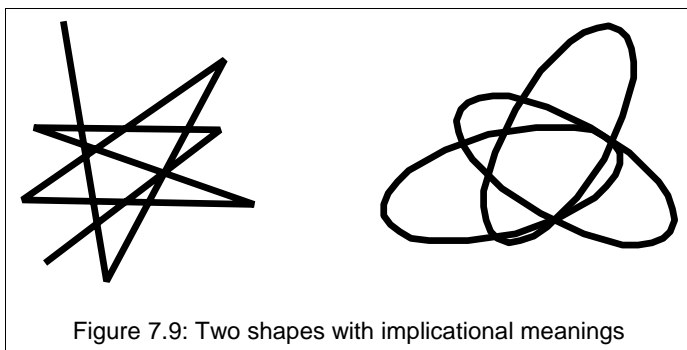

Figure 7.9: Two shapes with implicational meanings

Forms with implicational qualities have long been used in all sorts of interfaces from traffic signs (warning signs are triangular, 'requests' for drivers to obey are circular) to military radar displays (Figure 7.10). The use of shape to provide implicational representations directly can be an extremely useful way of communicating abstract information rapidly, but it is also very difficult to quantify and to prescribe.

Because the sensory subsystems provide implicational representations directly, it can become available before the perceptual and propositional subsystems have processed the explicit meaning of information. The

affective tone of information may be interpreted and fed back to the propositional subsystem in advance of the perceptual subsystems' contribution. This is how the fine nuances of gesture, intonation and facial expression can affect our

interpretation of speech, preparing us for the desired propositional interpretation of otherwise ambiguous linguistic phrases.

While the use of facial or intonational cues is useful when it is accurately related to the intended meaning of language, there can obviously be problems if it is unrelated. Computer-generated speech is notoriously lacking in intonation, and this has limited its widespread use as an output medium, despite its apparent advantages in many situations. Its only real application at the moment is in systems that provide automated responses via the telephone, such as banking services and speaking clocks, where the range of language is generally unambiguous, and would not benefit from intonational fluency.

Automated faces face the same problems. Figure 7.11 shows two very slightly different version of a face that was used to accompany spoken instructions to some people filling in a questionnaire by computer. Users who were asked the questions by the ‘stern’ version on the right spent longer writing their answers, wrote more, and made fewer mistakes than the people who saw the ‘neutral face’, but the liked the experience and the face less. The affective content of the face changed the way that users interpreted the questionnaire session as a whole, with the negative implications produced by the stern face giving an innocent question and answer session the characteristics of an inquisition.

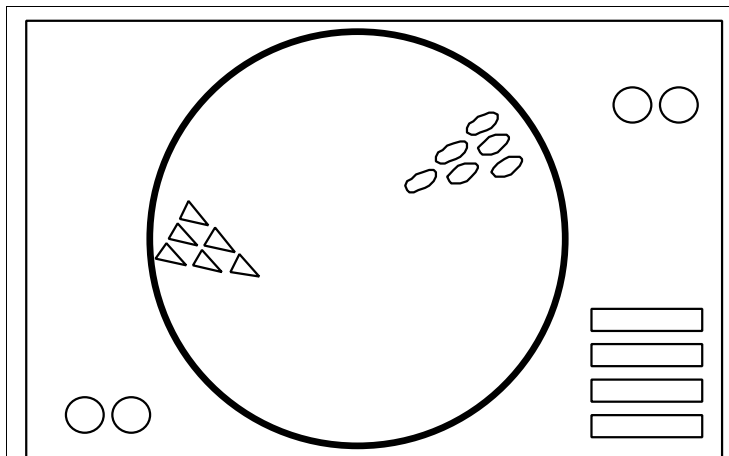

Figure 7.10: a schematic view of a military radar showing ‘friend’ and ‘enemy’ formations

Consequences of blending

In this section we have described different ways in which multimodal information can be combined, reflecting the four central levels of representation in ICS. In designing interfaces that do use multimodal features, it is important to identify the level that they are intended to be blended at, and to select the way that the information is presented accordingly. The use of sound in addition to visual objects will only help if the morphonolexical-to-object transformation is able to produce propositional representations that can be blended with those from the object-to-propositional transformation.

In general, we can say that there are two classes of multimedia interface. One relies on the blending together of implicational representations that have been produced directly from sensory information by the visual and acoustic subsystems. Because these result in an implicational representation, this is a qualitative sort of perception, that can give rise to an awareness of the general meaning of events in the world.

The second sort of multimedia interface relies on the structural interpretation of sensory information to produce object and morphonolexical representations, which are then used to produce propositional representations. When these are blended, the sound and vision can be attributed to a single event in the world, which can be named or identified.

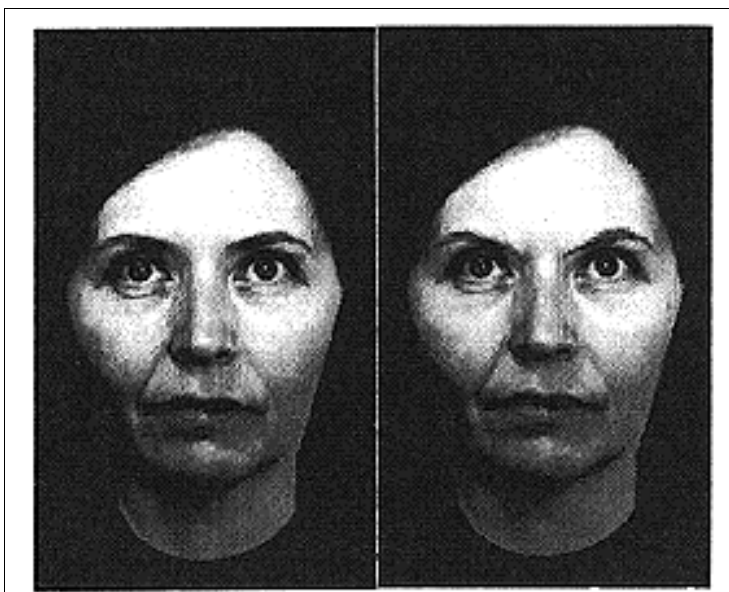

Figure 7.11: ‘neutral’ (left) and a ‘stern’ (right) faces used to accompany auditory questions to computer users



Multimedia interfaces rely on either propositional or implicational blending

•8• Applying the techniques

Icons for multivariate information

Some designers have tried to make use of our skills in the recognition and identification of complex graphical forms to represent complex ‘multivariate’ data with icons. Multivariate data is obtained when things are measured on several variables at the same time. For example, a house can be measured on its price, number of bedrooms, distance from the station, and so on. These measurements could be shown quite concisely in a numerical table, with a row for each house, and a column for each measurement, but trends that involve more than one variable are hard to detect from numbers alone. House price may be directly related to the number of bedrooms, or the distance from the station, for example.

Graphs that plot one measurement on the horizontal axis and another on the vertical axis are better, since the spatial groupings and positions within the area of the graph directly show the relationships between two variables. Even four measurements require six graphs to show all of the pairwise relationships: and they cannot show relationships that involve more than three variables at all.

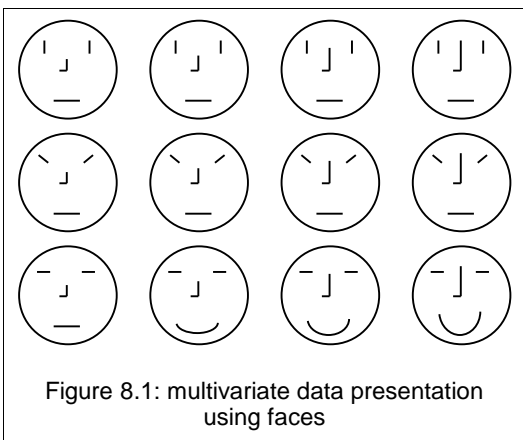

The icon solution tries to represent each measurement by a different attribute of an object, and then rely on the viewers’ ability to use propositional knowledge to concentrate on the relevant parts. In Figure 8.1, each of the ‘faces’ has three attributes that can change: the size of the nose, the curve of the mouth, and the angle of the eyes can each vary independently. If the nose represented a house’s price, the mouth its number of bedrooms, and the eyes its distance from the station, the viewer of this array could use their propositional knowledge to generate a mental image (an object representation) of, for example, a medium nosed, flat mouthed, slant-eyed face, and then search the array for that icon. In practice this system has proved hard to use. If we look at the structure of these faces, they resemble the control-panel icons of Figure 4.6 and the representational word-processing icons of Figure 4.1: they all have the same general ‘shape’ and border. The faces therefore form an array, but no subgroups, and require search

within the structure of each face to get information about how the faces differ, and therefore about the variables that the users are required to judge. As with the control-panels and word-processing icons, this predicate search requires transitions up and down within the structure of each icon, as well as transitions between the faces, which slows search down. The search and comparison of the face icons is represented in Figure 8.2.

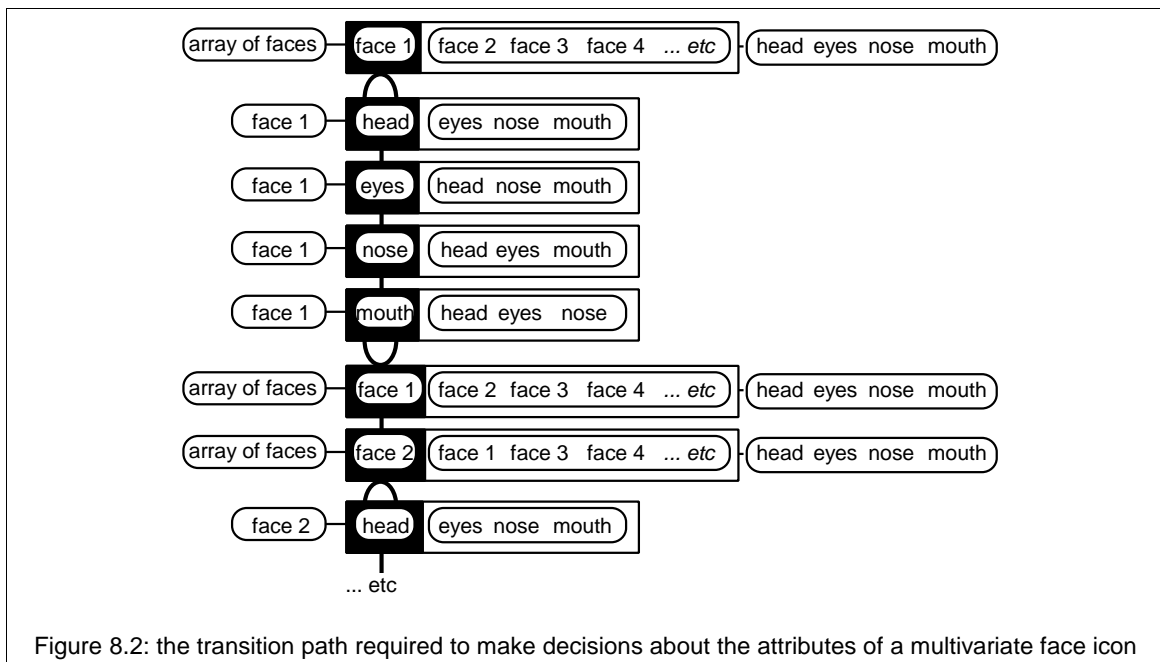

This is an example of the visually derived object representation being too strong for the propositionally derived knowledge to influence. With practice, users of the face icons can certainly generate a target image to search for, but it simply isn't possible for them to group the faces according to any particular attribute or combination of attributes.

A second family of icons to present multivariate data uses the structures of stick men (Figure 8.3). In this system the different dimensions are represented by varying the head size, body size and slant of limbs. We have shown that attributes like these can affect grouping in very simple visual items. In experiments, this system of representation is easier for subjects to use.

Because these stick men have no pragmatic subject, the propositional knowledge can now influence the object representation. Any one of the different attributes could form the psychological subject. In practice, this means that a stick-man (or a group of stick-men) with a different value to its neighbours for any one of its attributes can be made to pop-out, and be easily identifiable, provided that the user of the array is 'concentrating on' that attribute. Furthermore, an object representation of the target will now have as its subject the same attribute that has been used to group the objects in the array. This representation can then be used to drive the search, rather than letting it be constrained by the visual features of the array. This reduces the need for predicate depth search and shortens search time.

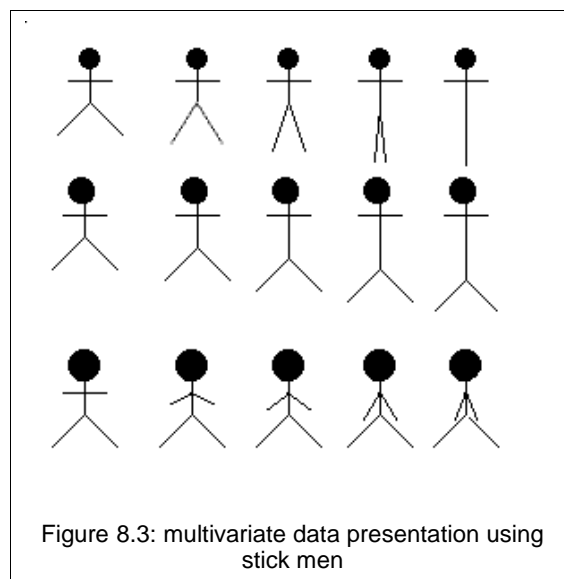

Figure 8.3: multivariate data presentation using stick men



If propositional representations can be used to group objects as well as to generate a target to search for, search is easier and quicker.

Dynamic changes in structure

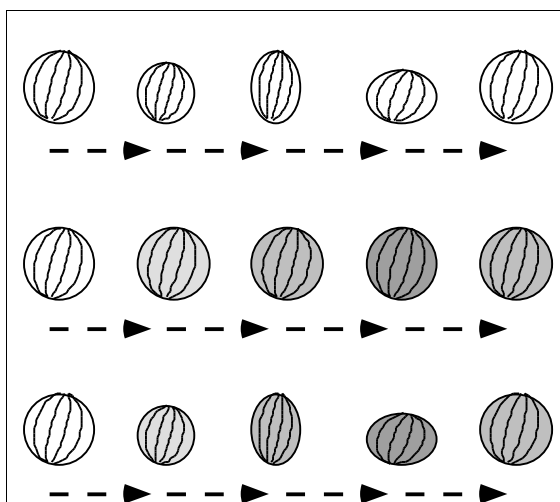

Figure 8.4: a dynamically changing ball can be seen as such (top two rows) if the changes over time are not too great (lower row).

The examples so far have concentrated on static screen displays – ones in which nothing moves. Clearly, motion affects the structural attributes of displays: one moving object against a static background is very likely to pop out, and grab people's attention, regardless of its other attributes. If many objects move in an unco-ordinated fashion, the result is just going to be confusing, and very hard to make sense of. Between these extremes you might be able to see how the principles of grouping that we have presented for static attributes can also apply to dynamic attributes.

Consider a group of people walking along a street. Unless they are an army marching in step, they will all move at slightly different speeds, and yet we can perceive them as a group, because they all move in *roughly* the same direction, at *roughly* the same general speed. Similarly, a few screen objects with similar attributes of motion can be perceived as a single 'group' moving on the screen.

Other attributes can also vary over time - an object might change colour, size, or shape, for example. This is a key principle in animation, and allows us to see differently drawn views of an object as the 'same thing' changing, rather than as 'different things', replacing each other. For this to work perceptually smoothly, the viewer must be able to construct a smoothly changing object representation, and so the visual changes must not be too great. In the top row of Figure 8.4, a ball changes shape over time. If this were an animation, we would easily see this as a single, changing ball, rather than as separate balls replacing each other. In the middle row, its colour changes but its shape remains constant. Again, it is easy for us to see it as a

single, changing ball.

In the lower row, both of these attributes change at the same time. Now it is harder (although still possible) for us to see it as a single ball. This sequence of changes, if animated, appears much less ‘smooth’, and it feels as if we are seeing several different balls. This is because the overall change in the attributes of the ball has become too great for the visual-to-object transformation to produce an object representation that can coherently blend with ongoing processing, in particular the product of the propositional-to-object transformation, which was based on the object representation of the previous ball.



Objects that change over time can be perceived as the same object, if the changes can be propositionally blended.

Animation is a familiar example of dynamic, changing objects that can move on the screen. Ordinary films also tell us something about the management of dynamic changes in display design. Over the last century, film-makers have developed editing techniques that allow them to cut from camera to camera, dramatically changing the structural contents of the visual scene, without confusing or misleading the viewers of their films. They can jump spatially between different viewpoints within a scene, or temporally, skipping over periods when nothing interesting is happening. They can even intercut different scenes without confusing us.

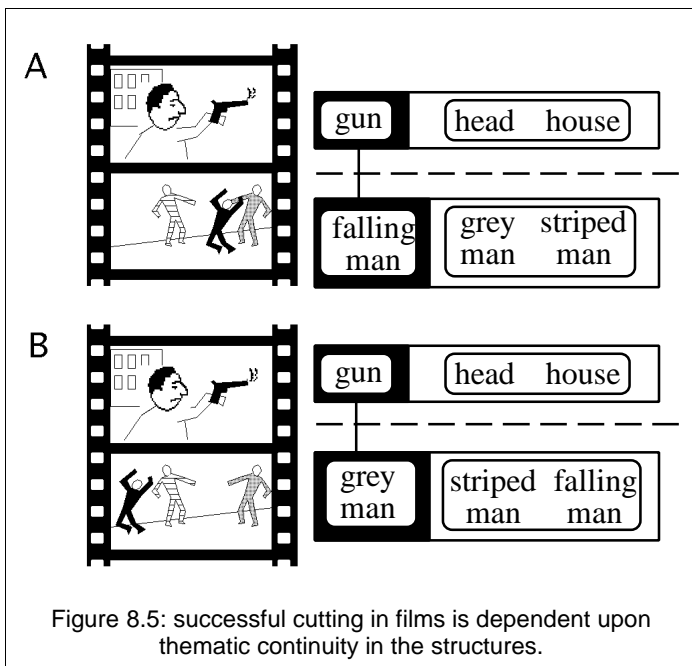

Many of the rules of thumb that film-makers follow when cutting films together have to do with the content of the narrative, but others have to do with structural details of the shots either side of the cut. When a film-maker cuts from a view of someone firing a gun, to a view of his victim falling, a conventional cut will place the victim in roughly the same screen location as the gun (Version A of Figure 8.5).

Before the cut, viewers will have been watching the man raise the gun, and they are likely to have had the gun as the psychological subject of their object representation. When the cut occurs, they will be looking directly at the falling man, and so this will form the immediate pragmatic subject. Since this fits coherently with their ongoing propositional comprehension of the scene, providing ‘thematic continuity’, the cut makes sense and seems perceptually smooth.

Version B of Figure 8.5 shows an unconventional cut. The falling man is not ‘collocated’ with the gun, and so following the cut, the viewer has to search the scene to

find an object that makes propositional sense. This cut feels less perceptually smooth. This type of cut is more likely to be ‘noticed’ as a perceptual ‘jump’ because it does not provide thematic continuity.



Thematic continuity, through collocation of objects that are visually or propositionally related, helps users orient themselves over screen changes.

A similar use of collocation is made when film-makers zoom-in to a scene to provide greater detail on some object. Here the rule is that the same object should be the subject of the before and after shots, and that it should be collocated with itself. Clearly, to do this the film-maker needs to ‘know’ what it is that the viewer is going to be looking at, and so they will often try to direct the viewers’ attention towards the object that they are going to zoom-in to. An actor might pick the object up, or direct their gaze towards something, so that the viewers also look at it.

Many applications need to change screen displays, so that all of the information changes. The advice of film-makers would be to provide some thematic continuity over the screen change, just as they do over cuts. An example of this sort of design problem can be seen in Figure 8.6, where a tourist information system was being implemented on a PC. The screen had to display a large scale overview of the whole area (the left screen), and allow people to ‘zoom-in’ by clicking on a particular place (right screen)

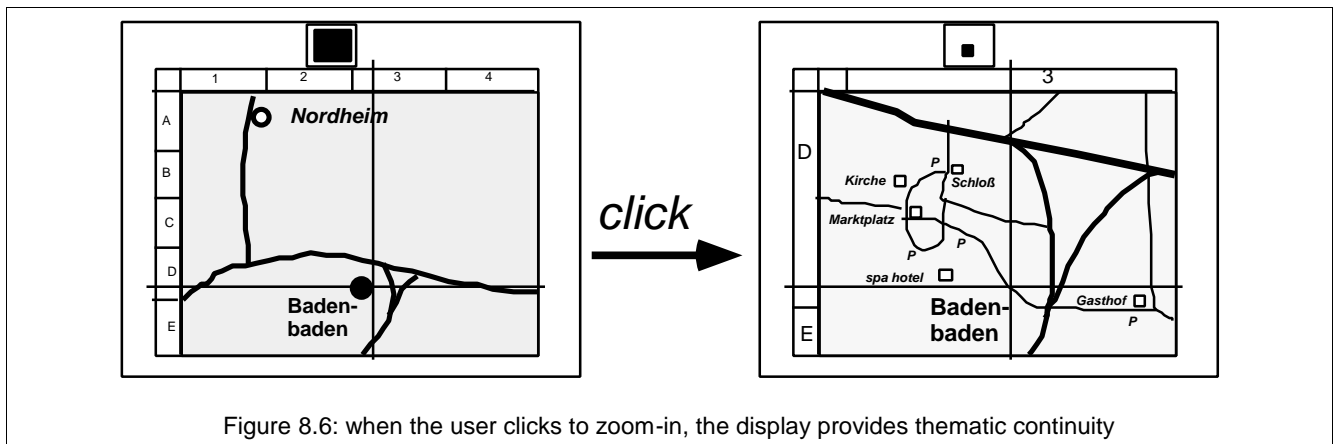

Figure 8.6: when the user clicks to zoom-in, the display provides thematic continuity

Just before the user clicks, they will have moved the cross-hair to the area they are interested in, and will be attending to that part of the screen (perhaps to the name of the city, to the blob marking its position, or to the road layout). After the screen zooms-in, the display preserves some of these objects, and collocates them. If the user had been attending to the name or to the road junction, then these objects would still form the psychological subject, even though their size has increased (Figure 8.7).

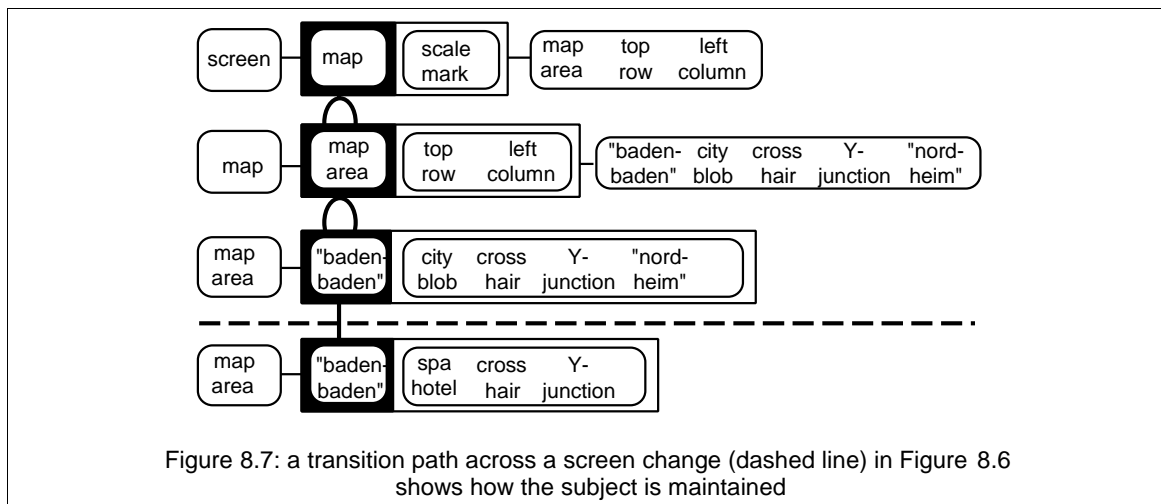

Figure 8.7: a transition path across a screen change (dashed line) in Figure 8.6 shows how the subject is maintained

This would give a sensation of 'getting closer', as well as providing thematic continuity, so that they would not have to search around the screen to find out what had happened. The 'city blob' has disappeared, of course, so if they had been attending to this they might be a little less sure of what had happened, but several objects of the predicate would remain (the name and the junction), and these too could provide some thematic continuity.

Summary

This Guide has provided an overview of a framework for understanding human perception and cognition. The framework, ICS, consists of nine independent cognitive subsystems, which each operate on a different level of mental representation. Each subsystem has a common architecture, with a memory and set of processes that transform their level of representation into other levels. The flow of information between the different levels, and the interaction of the cognitive subsystems, gives rise to the richness of human cognition and perception. Because of the common architecture, each level of representation can be analysed using the same structural techniques. All representations consist of a group, subject-predicate and constituent structures. Structure diagrams and transition path diagrams can be used to show how the focus of processing can move over time, and how representations from different sources can be combined.

Our visual perception is a result of a blend of information that is derived from visual sensory representations and propositional knowledge. Our perception of sound is a result of a blend of representations from acoustic, propositional and also object sources. The propositional subsystem blends the perception of sight and sound with our implicational understanding of the situation. Our implicational understanding is based on a blend of propositional knowledge and qualities derived from sensory information, including the state of our bodies.

Understanding the interactions between these levels of representation can help interface designers. Screen displays can be designed so that objects group together to match the structure of the user's tasks. Task structures can be designed to avoid ambiguous steps. Multimodal interfaces can be designed so that sight and sound can blend appropriately, either propositionally or implicationally.

Hints for structuring displays

- 1 Consider what objects you want to appear on the display.
Does the presentation on the screen actually form these objects?
Are the individual objects recognisable as propositionally nameable entities?
- 2 Do the objects on the display form groups, or a hierarchy of groups?
Do you have an array of icons, or a display containing smaller windows which in turn contain further structures?
Draw the **Structural Diagram**, and be careful to consider the structure of the different objects, and whether these contain smaller objects that the user can interact with.
- 3 If the user has to search for objects in the display, what mental image (object representation) will they form?
What attributes of an object can they use to discriminate it from its neighbours?
Do these attributes help the target pop out from the background?
Remember that a user might use different propositional knowledge, and so the structure of the object representation might vary.
- 4 When the structure diagram is drawn, think about the visual transitions users will make, and draw a **Transition Path Diagram**.
What sequences of tasks are users going to perform with the display?
What will the transition paths look like?
Are there ways you could speed up the tasks by avoiding transitions between levels of structure?
5. How is the user's task structured?
Where is the most ambiguous part of the transition path diagram going to occur?
Can the ambiguity be reduced by changing the task?
Check again that the object structure and the propositional structure match.
6. Does the system use sound as well as a display?
Will the sound perceived be affected by the display?
Can the sound be propositionally blended with the interpretation of the display?
Do the qualities of the visual and acoustic information provide any implicational cues that might affect the user's propositional interpretation or mood?

Answers to Exercises

Exercise Set 1

These figures are intended to show that although there may be several possible ways of structuring the groups, there is usually one 'perceptually obvious' way. Here we only include the structure of this obvious grouping. The less obvious structures are not 'wrong', but they require effort to impose upon the groups.

Note also that we have not always included every single circle and square in the figures - just enough to make it clear what ought to be represented.

The precise terms that are shown in the diagrams are not important - we have shown each as starting with 'set', but the words themselves are not crucial. Group, Array, or Pattern would all serve just as well, and there are undoubtedly many other synonyms. These are just 'labels': what is being described is more important. In some cases we have drawn the objects themselves rather than use words.

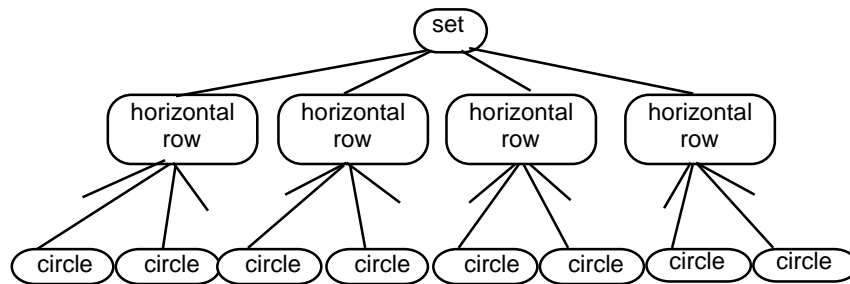
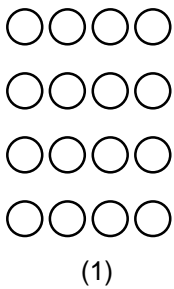

Here the attribute that is 'causing' the circles to be grouped into rows is **proximity**.

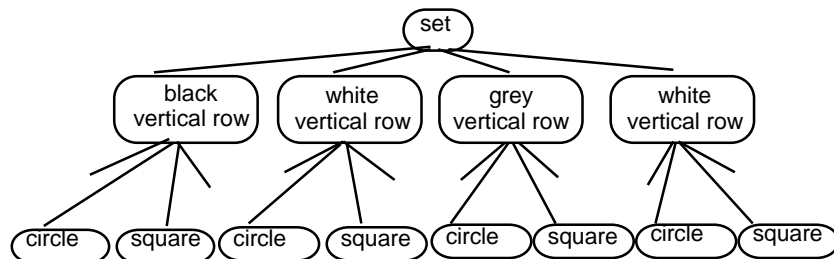
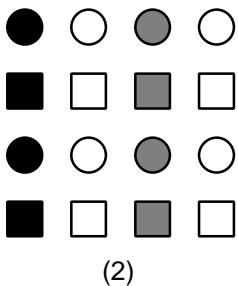

In this and the next figure, the similarity of the shapes in each row suggests that the second level of the structure could be rows - but in this figure the **colour** of the columns predominates.

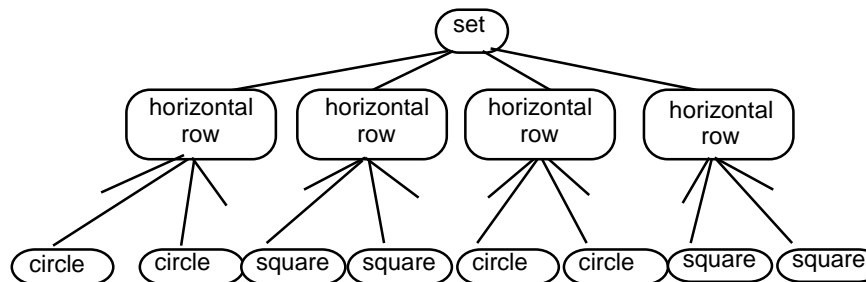
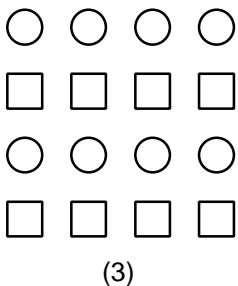

When the colour is removed from (2), the similarity of **shape** dominates the structure, and the rows become the second level of structure.

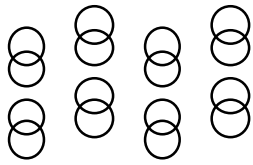

(4)

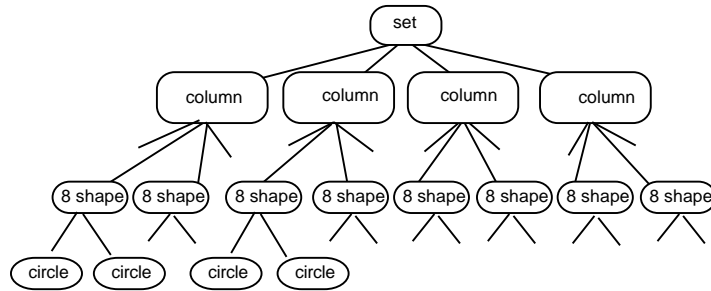

This figure has circles grouped by **collocation** into 'figures of eight' or '8 shapes', but the grouping of these shapes is ambiguous. You might represent them as columns, wavy horizontal rows, or even groups of four (in a rhombus). There is some structure there though, so the diagram should have four levels.

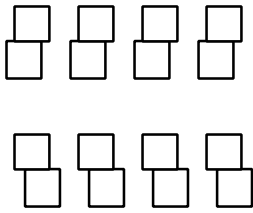

(5)

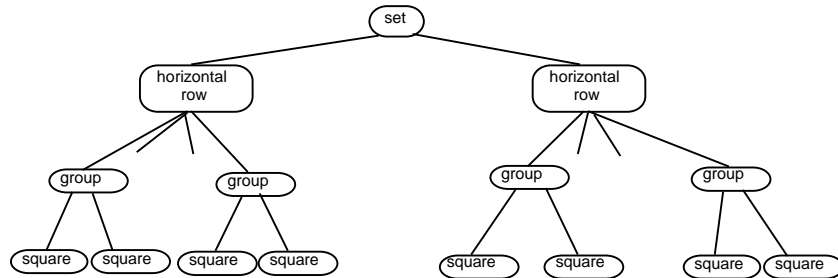

Here the squares are joined at their **boundary** into groups, and these groups then form rows due to their **proximity** to each other. Note that if the slight horizontal offset of each square were not present, the eight groups would look like rectangles with a line across the middle, not two squares.

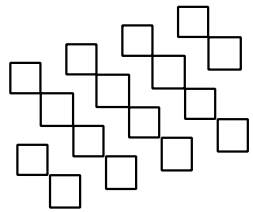

(6)

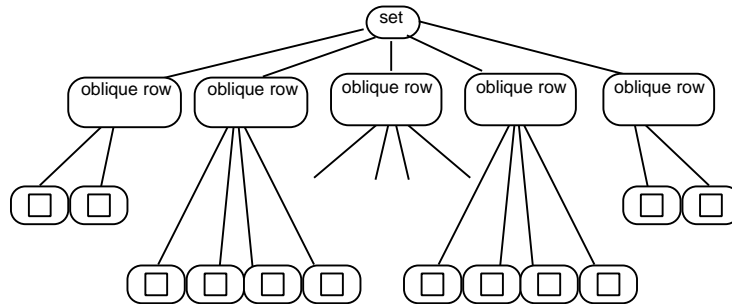

Now the **junction** of the squares links them into five oblique or diagonal rows, although some rows have two and some four elements. The presence of the 'pairs' at each end might lead you to see the centre three rows as also being composed of two pairs, adding another level of structure to the diagram.

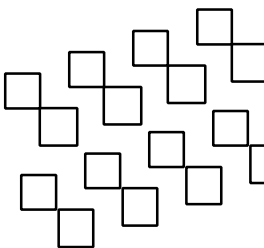

(7)

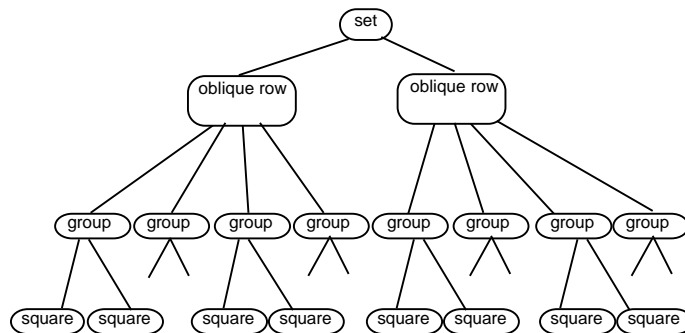

This figure is exactly the same as (6), except that a slight gap has been introduced into the middle of the three central rows. Instead of just breaking the structure up into eight pairs, two new diagonal rows emerge (**proximity**). This figure shows that there are often several different grouping principles competing to provide organisation, and that when one is weakened, another may take over.

Exercise Set 2 Question 1

This exercise shows how the transition path diagrams represent the more complex search in the right hand group. The presence of the black circle makes it harder to 'zoom-in' to the substructure of the white group distractor.

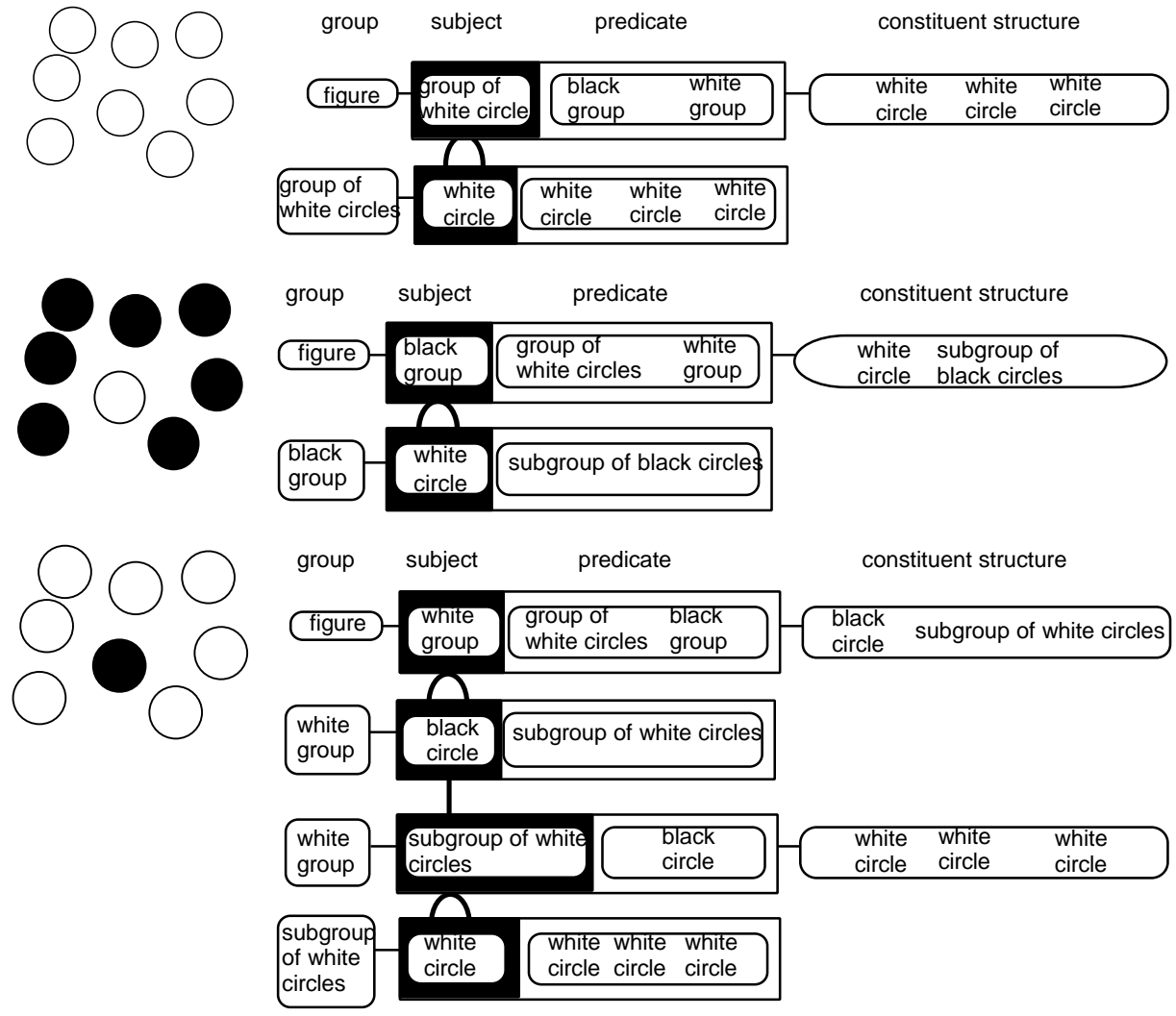

Exercise Set 2 Question 2

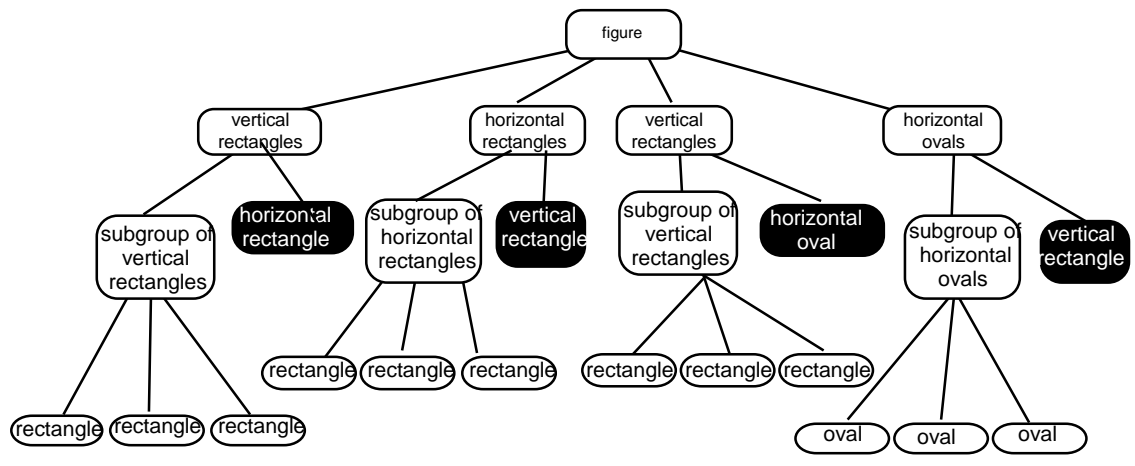

Exercise Set 2 Question 3

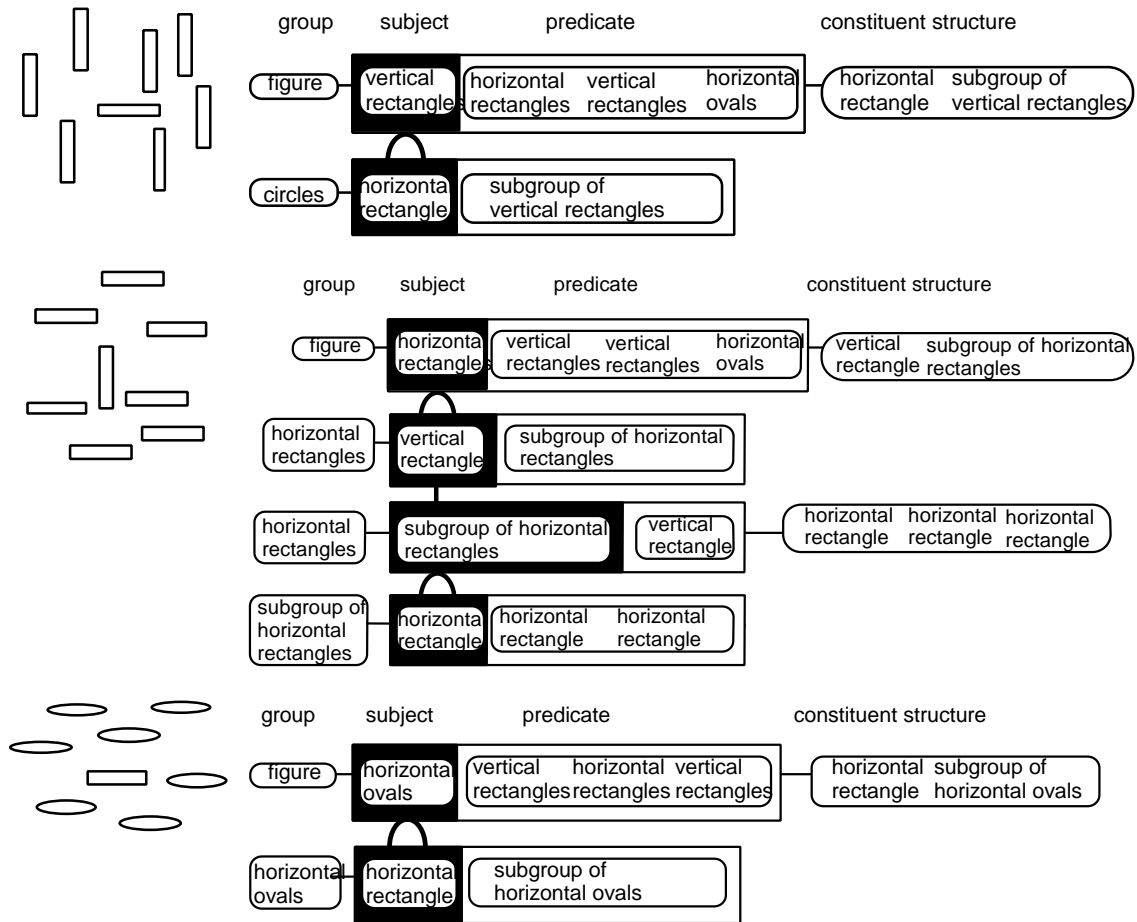

Exercise Set 3 Question 1

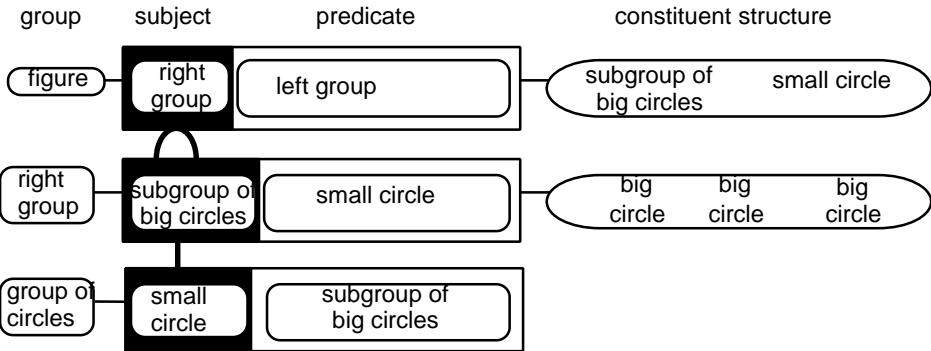
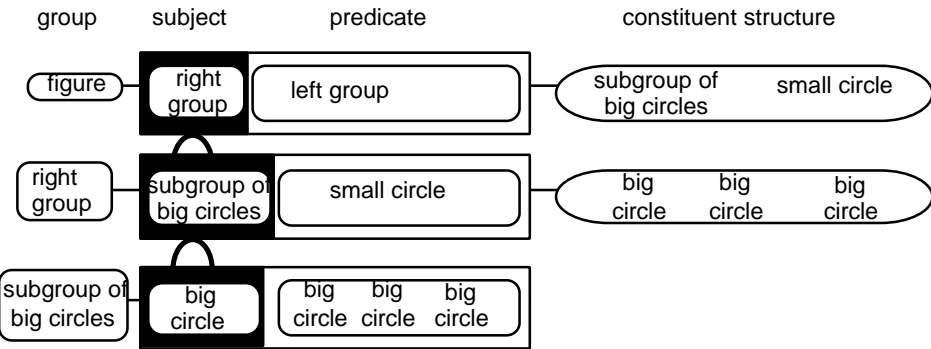
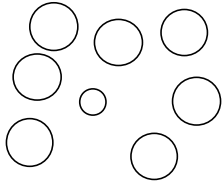
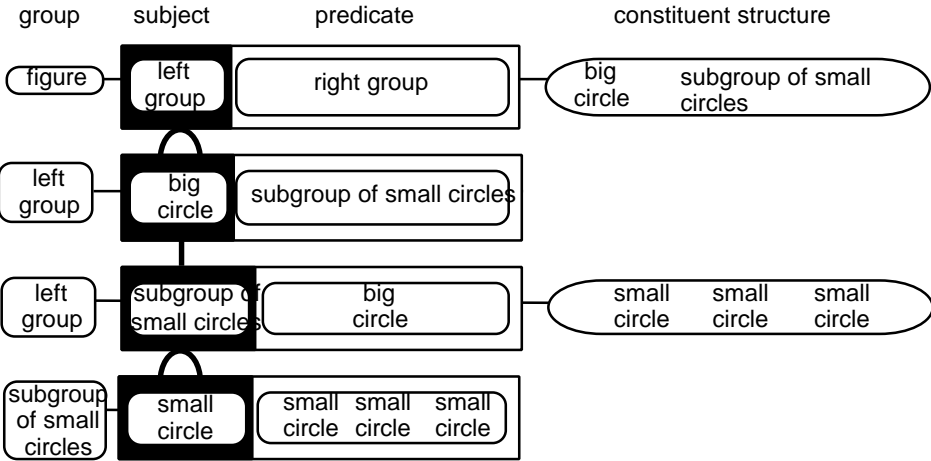
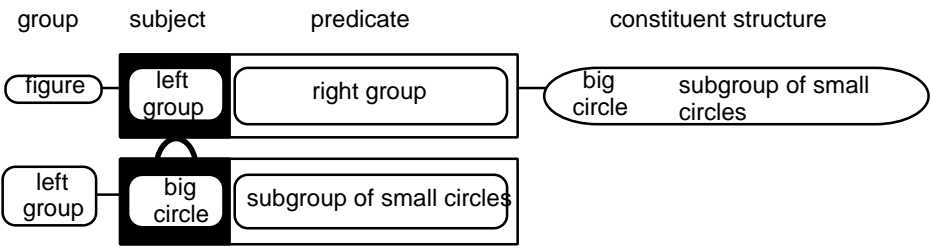
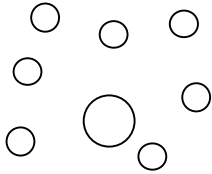

Exercise Set 3 Question 2

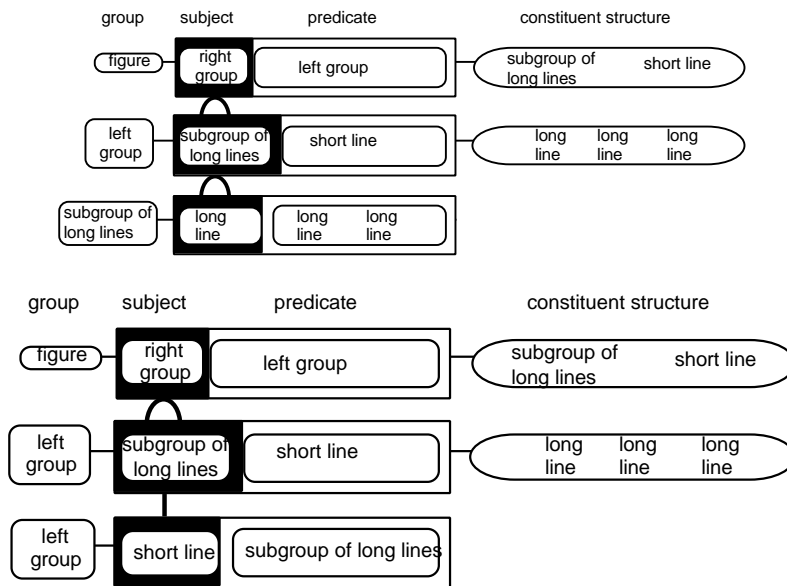
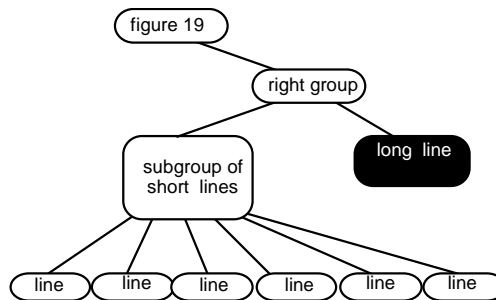
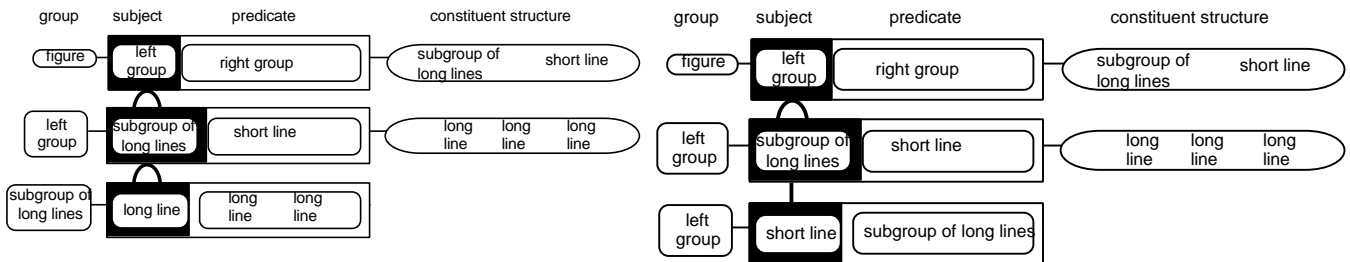
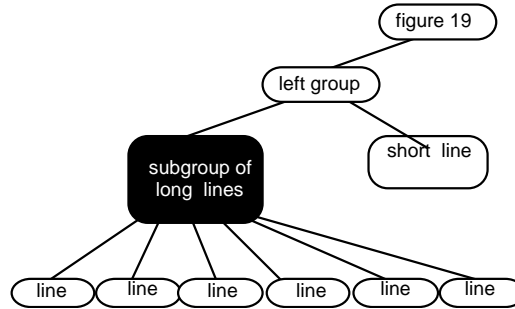

Exercise Set 3 Question 3

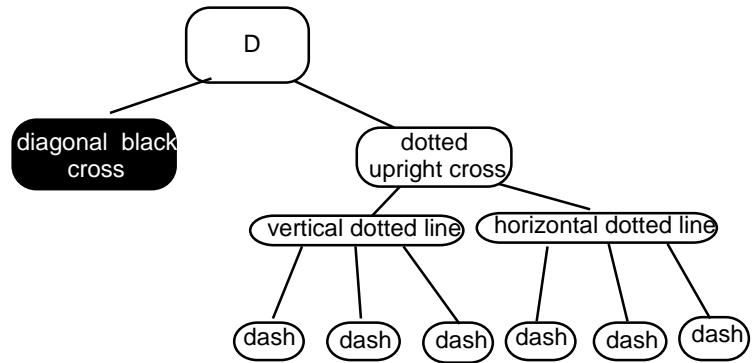
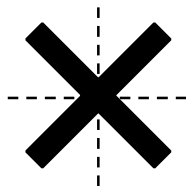
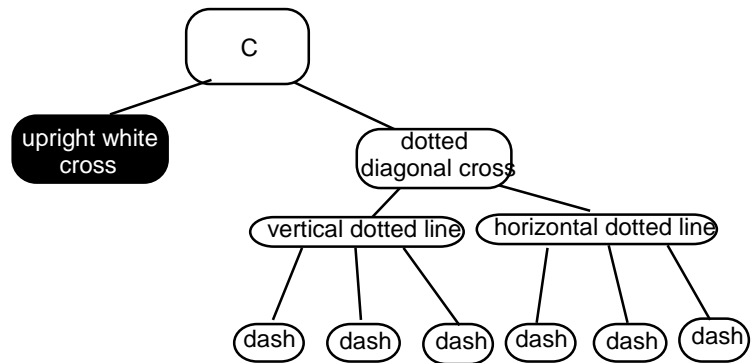
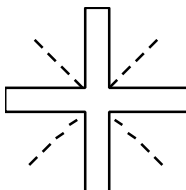
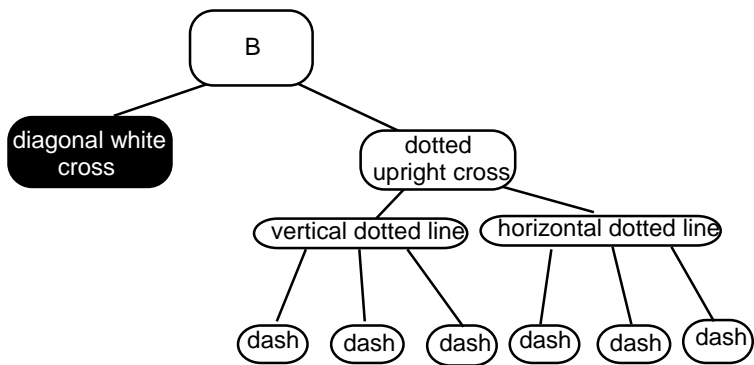
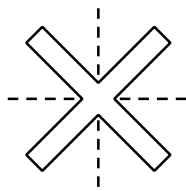
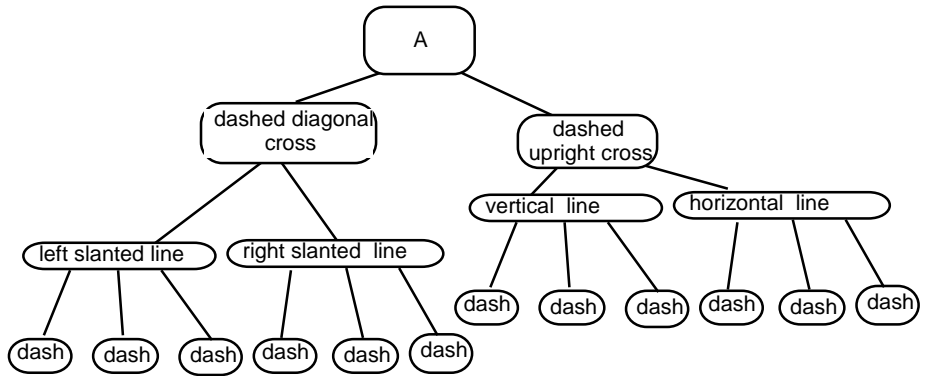
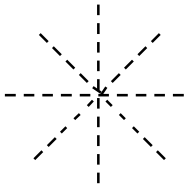

Exercise Set 3 Question 4

Of these icons, A, B and D all have only one transition represented to make the diagonal cross the subject, while in C the upright cross is the pragmatic subject, and so an additional transition is required. This means that the diagonal cross in C is the hardest to attend to.

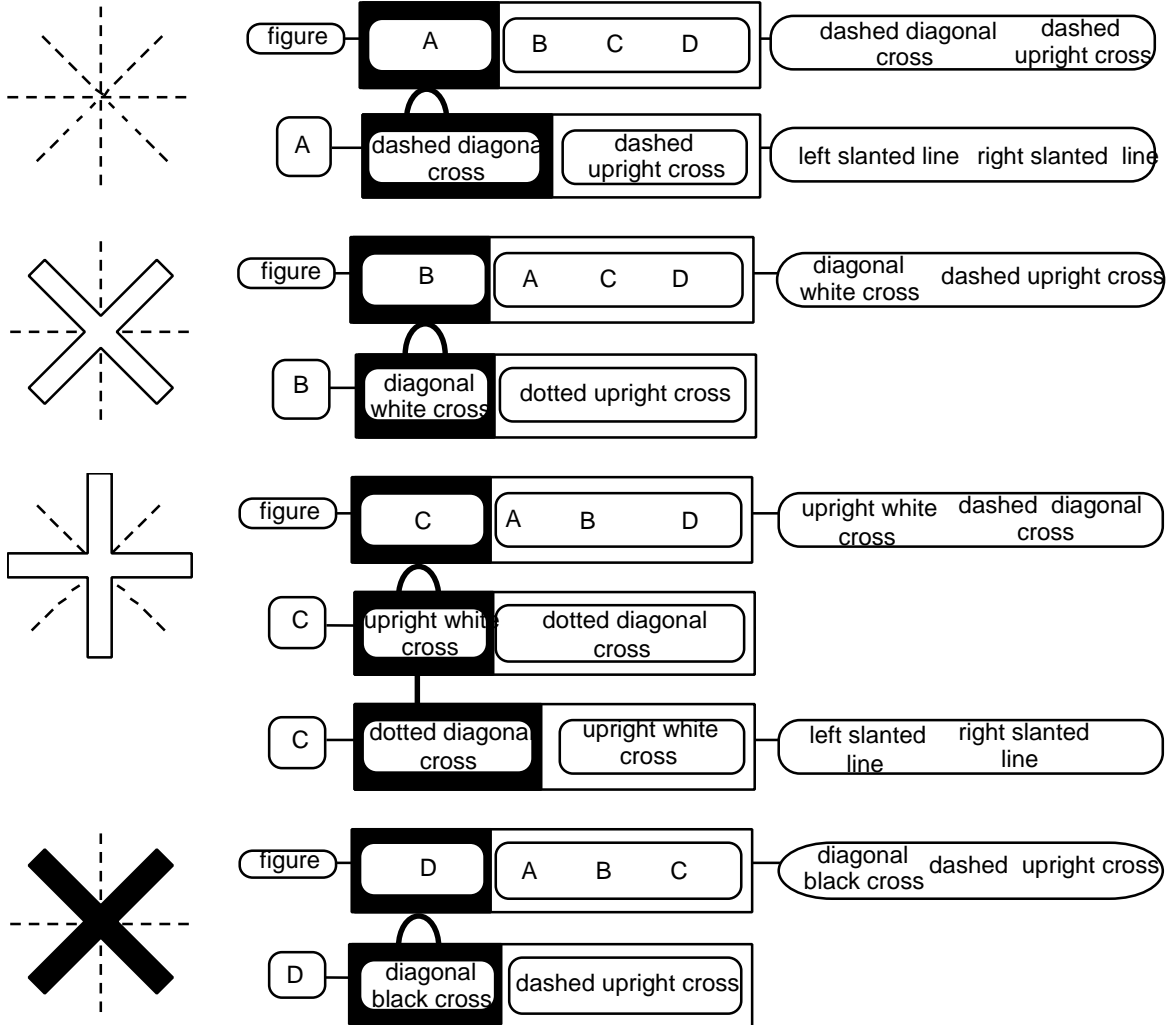

Exercise Set 4 Question 1



delete line

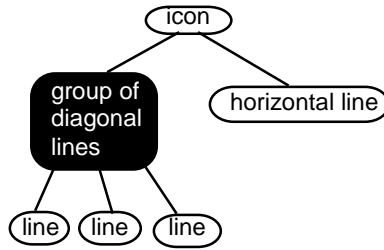

word search

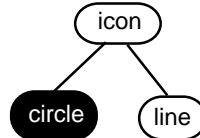

replace word

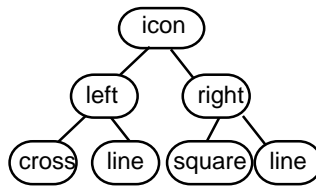

scroll right

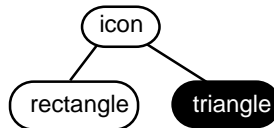

Exercise Set 4 Question 2 & 3

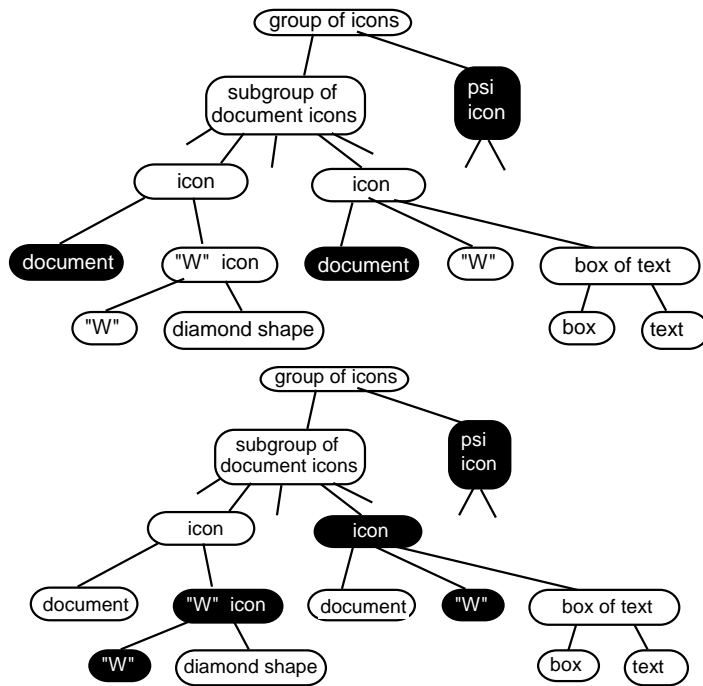

Exercise Set 4 Question 4

The document shape is common to all of the document icons, and so having it as the pragmatic subject does not help distinguish between them. Additional transitions are required to examine the distinguishing features of each icon (or the textual label, although we are not including these in the structure here). The 'blending text' icon differs in the location of the W and the 'box of text', and so if either of these were the pragmatic subject then the icon could be found easily, since the discriminating feature could be found without a transition. Since it has a different pragmatic subject to the rest of the subgroup, it may actually 'pop-out' from the others. We have shown this in the answer to 4.3 by highlighting the 'icon' that it belongs to – you could also add in another subgroup for all of the other document icons, to make this pop-out effect obvious.

Exercise Set 5 Question 1 & 2

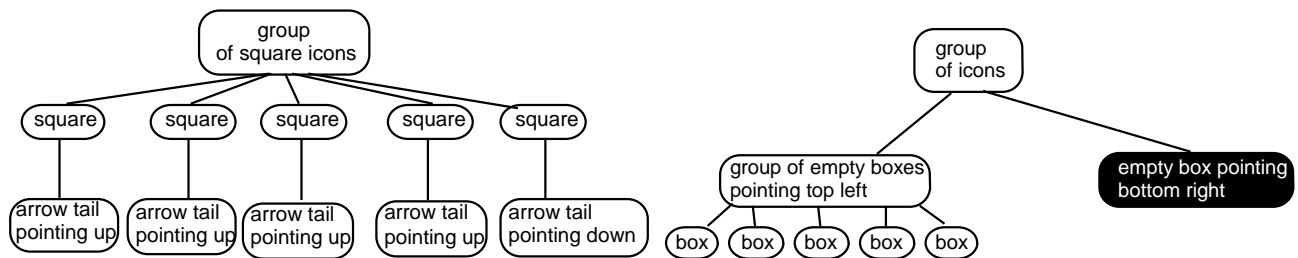

Exercise Set 5 Question 3

The 'blending text' icon is the most complex, and so even when the document shape is the pragmatic subject it still 'pops-out' to a certain extent, although we have not shown this happening in the answer for Exercise 4.

Exercise Set 5 Question 4

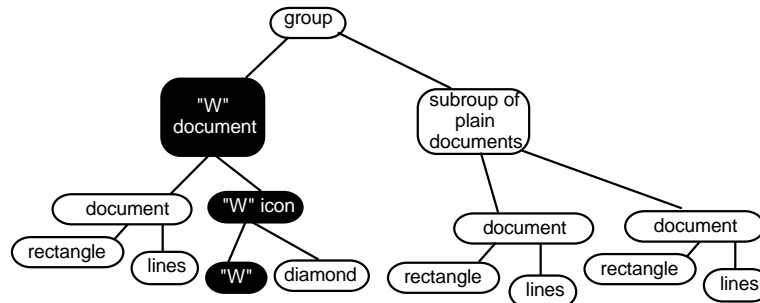
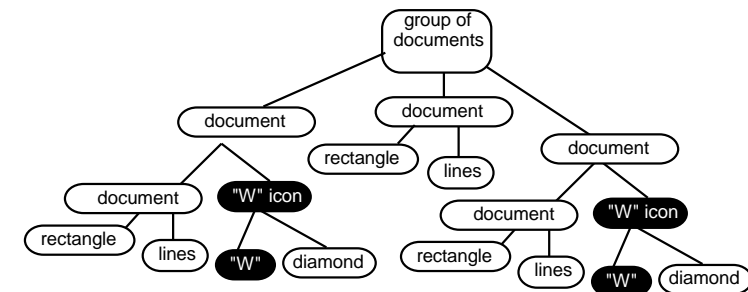

Exercise Set 6 Questions 1-4

As the figures below show, only the subgroup in part d has a pragmatic subject, which stands out from the rest of the black group on account of its different shape. It is therefore easier to find this oblong than the differently textured oblong in part f, which does not form a pragmatic subject (texture here not being a grouping cue).

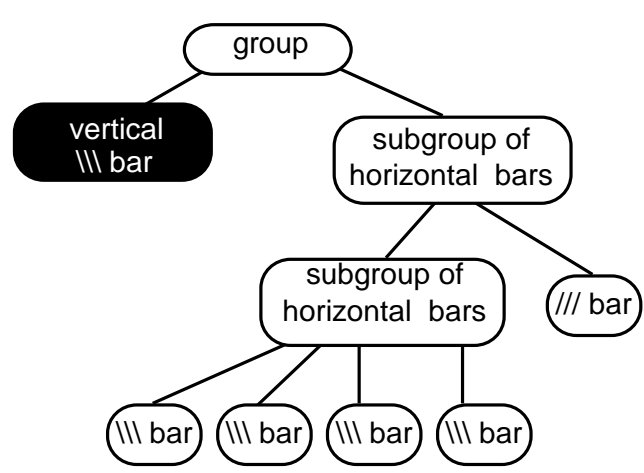
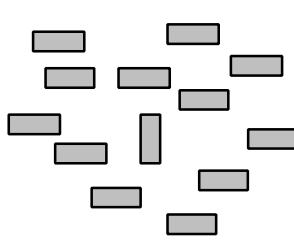
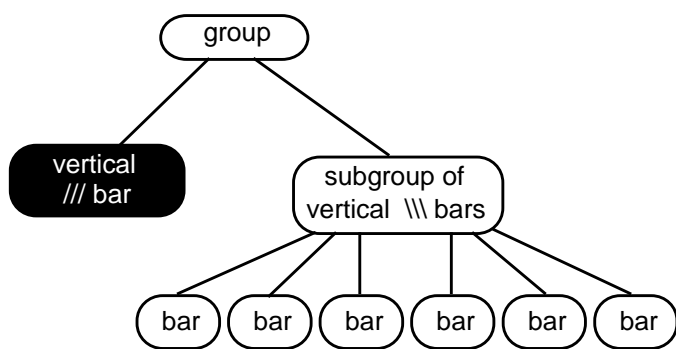
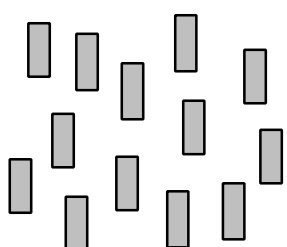
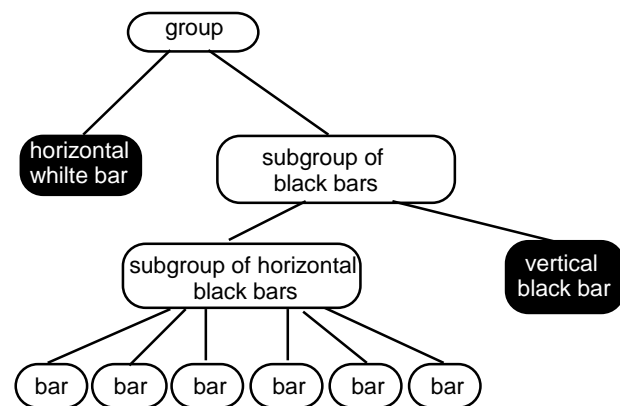
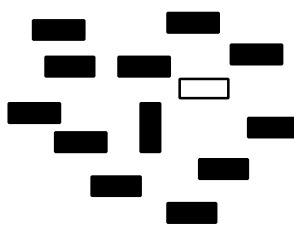
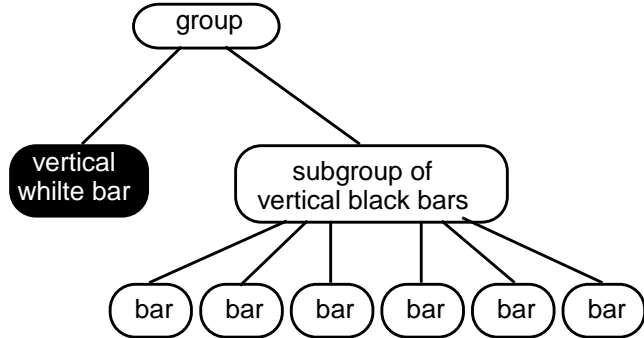
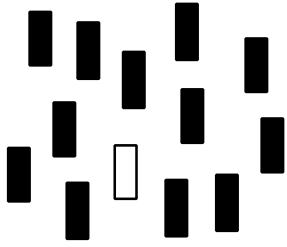

Exercise Set 7 Question 1

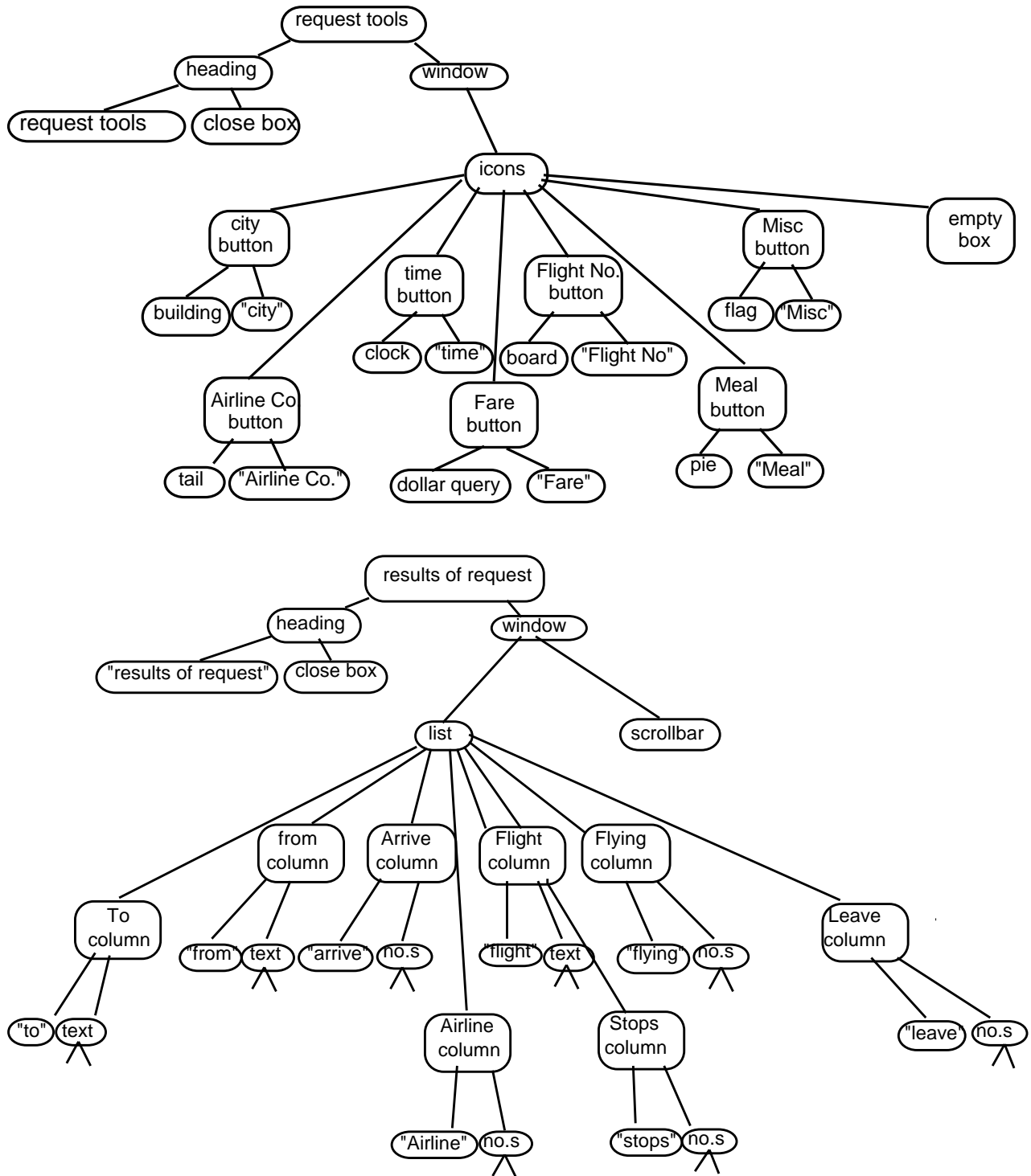

Exercise Set 7 Question 2

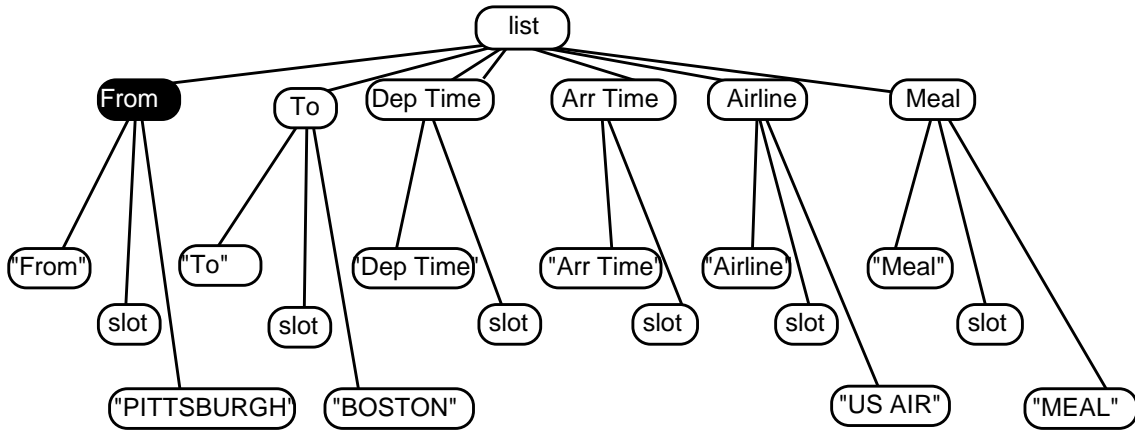

Exercise Set 7 Question 3a

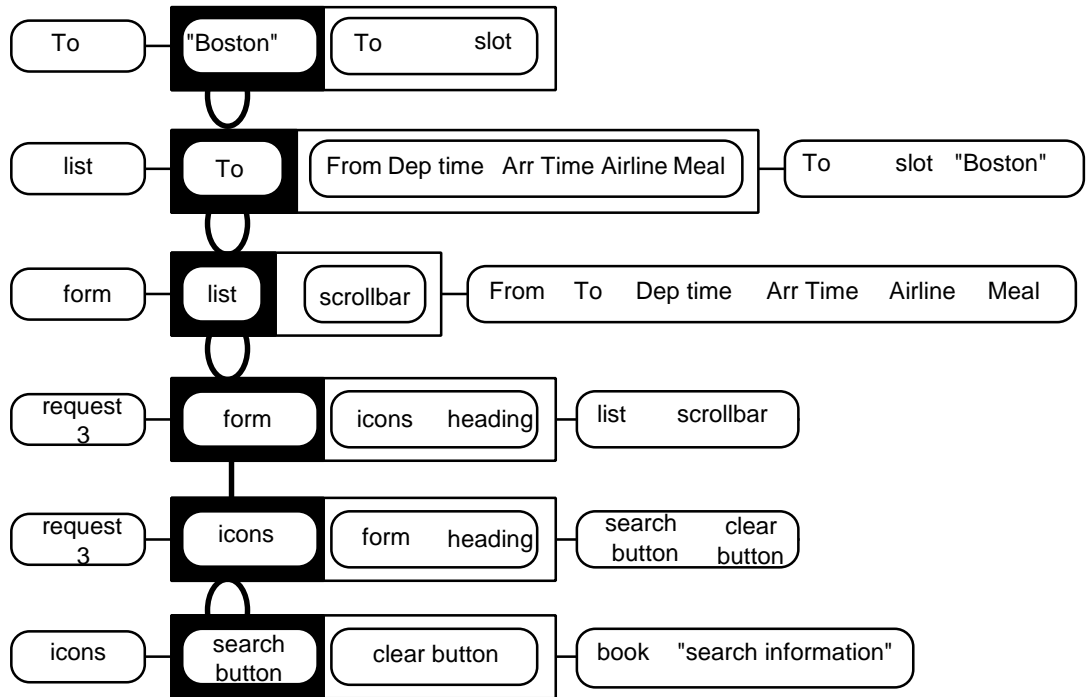

Exercise Set 7 Question 3b

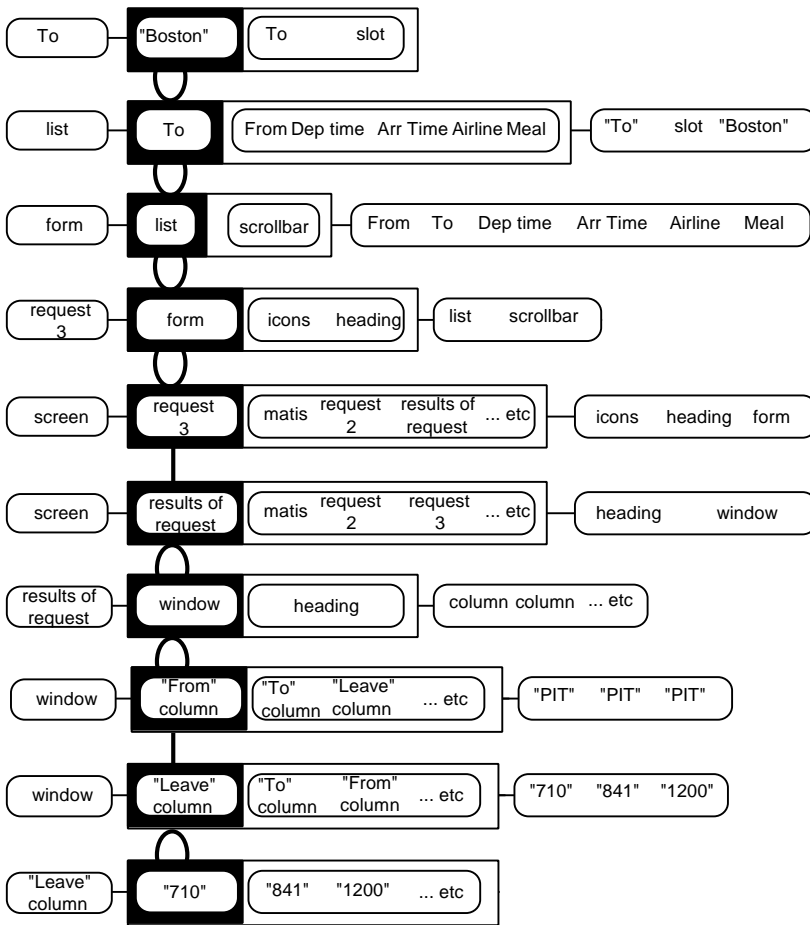

Exercise Set 7 Question 4

Having just filled in the 'Dep Time' slot, the user will still have a mental image of this phrase. The corresponding column in the results window is headed 'Leave', and so they may not realise that it is the one they want. Making the label for the slot in the Request and Results column correspond to each other would be best, whether they both say 'Dep Time' or 'Leave'.

Exercise Set 7 Question 5

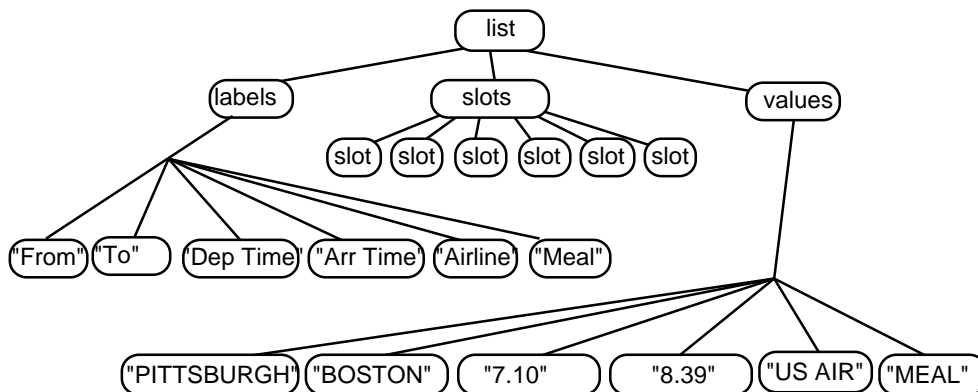

Sources of examples

The icon arrays shown in Figures 1.1, 1.2, 4.4, 4.6, and 4.8 are all taken from the Macintosh Finder, System 7.1.1.

The menu shown in Figure 3.9 is a (customised) version of one found in Microsoft Word 5.1a for Macintosh.

The representational and abstract icon sets shown in Figure 4.1 were first used by:

Arend, U., K-P. Muthig and J. Wandmacher (1987) 'Evidence for global feature superiority in menu selection by icons', *Behaviour and Information Technology*, 6, 411-426.

Other experiments carried out using these icons are reported in:

Green, A.J.K. and P.J. Barnard (1990) 'Icon Interfacing: The role of icon distinctiveness and fixed or variable screen location', in D. Diaper, D. Gilmore, G. Cockton and B. Shackel (Eds) *Proceedings of Interact '90*, Amsterdam: Elsevier Scientific Publishers B.V., pp 457-462

The analysis of the structure of the icons, and the graph shown in Figure 4.3, appeared in:

May, J., Barnard, P.J. and A. Blandford. (1993) 'Using Structural Descriptions of Interfaces to Automate the Modelling of User Cognition', *User Modelling and Adaptive User Interfaces*, 3, 27-64.

The 'cube' and 'empty box' objects shown in Figure 5.1 were first described by:

Enns, J.T. & Resnick, R.A. (1992) A model for the rapid interpretation of line drawings in early vision. In D. Brogan (Ed.), *Visual Search II*, pp. 73-89. London: Taylor & Francis.

The hypertext database shown in Figure 5.4. was developed by researchers at the University of York, and is described in:

Myers, K.J. and N.V. Hammond (1991) 'Consolidated Report of workshop on scenario matrix analysis'. Esprit 3066 'Amodeus' Deliverable D9, Dept. of Psychology, Univ. of York, UK

The experimental study that used the 'ordering system' described in Section 6 and Figure 6.3 is reported in:

Barnard, P.J., MacLean, A., and Hammond, N. (1984) User representations of ordered sequences of command operations. In B. Shackel (ed), *Proceedings of INTERACT'84*. London: IEE.

The 'MATIS' system shown in Figure 6.9 is described in:

Nigay, L. & J. Coutaz, (1995). A generic platform for addressing the multimodal challenge. In *Proceedings of CHI'95*. ACM: New York (in press).

The 'shared drawing' experiment in Figure 7.7 is reported in:

Barnard, P.J., May, J., and Salber, D. (1995) Deixis and points of view in media spaces: an empirical gesture. *Behaviour and Information Technology*, 15, 37-50.

Takete and Uloomoo were first described by:

Davis, R. (1961) The fitness of names to drawings. *British Journal of Psychology*, 52, 259-268.

The faces in Figure 7.11 are taken from:

Walker, J.H. & Sproull, L & Subramani, R. (1994) Using a human face in an interface. *Proc. CHI'94*, pp.85-91. ACM: New York.

The 'face icons' of Figure 8.1 were described in:

Chernoff, H. (1973) The use of faces to represent points in k-dimensional space graphically. *Journal of the American Statistical Association*, 68, 361-368.

The 'stick men' icons of Figure 8.3 were developed by:

Pickett, R.M. & Grinstein, G.G. (1988) Iconographic displays for visualising multidimensional data. *Proceedings of the IEEE International Conference on Systems, Man and Cybernetics*. Beijing and Shenyang, PRC: IEEE.

Index of Exercises

Exercise Set 1.....	20
Exercise Set 2.....	22
Exercise Set 3.....	23
Exercise Set 4.....	28
Exercise Set 5.....	29
Exercise Set 6.....	34
Exercise Set 7.....	43

Acknowledgments

The authors of this guide would like to thank Anker Jørgensen and Annette Aboulafia of the Psychology Department of Copenhagen University, and their many HCI students for their help in the development and evaluation of earlier drafts.

This is the fourth distributed edition of the Guide.

The third edition was used by the Mennesks-Maskine Interaktion Course of the University of Copenhagen, In Autumn 1996.

The second edition was prepared for a tutorial at Eurographics'95 in Maastricht, and has been published as:
May, J., Scott, S. and Barnard, P. (1995) *Structuring Displays: a psychological guide*. Eurographics Tutorial Notes Series. EACG: Geneva

The first edition of this Guide was written as part of the AMODEUS project: ESPRIT basic research action 7040, supported by the Commission of the European Union.



Index of key points

The structure of the scene constrains the way people can search through it.	9
The object that is being attended to is the psychological subject . Other objects in the same group form its predicate	9
Structure diagrams show the hierarchical relationships between objects. Transition Path diagrams show changes in the psychological subject and predicate in time.	9
Sensory information from the eyes forms a visual representation	12
Perceptual information is contained in an object representation	12
The visual-to-object transformation process structures and groups the visual scene	12
The object-to-propositional transformation process identifies and relates objects	13
The propositional-to-object transformation process feeds back information about object structure	13
The object representation that is perceived is a blend of information from visual and propositional sources.	13
Propositional representations can fill in gaps in object representations derived from incomplete visual representations.	13
Propositional representations help the object representation settle on one interpretation of ambiguous figures.	14
The perception of ambiguous figures depends on what the viewer knows, and what they expect to see.	14
Each level of mental representation is processed by a different cognitive subsystem	17
All nine subsystems have a common architecture , including their own memory.	17
The content of a memory depends upon the subsystem in which it is stored.	17
All levels of representation can be described as having groups, subject-predicate and constituent structures. Structure diagrams and Transition Path diagrams can be used for all levels of representation.	17
All perceptual and central subsystems receive representations from more than one source.	18
Visual information can affect the way that objects form groups.	19
Objects that are spatially close to a group, but not part of it, seem to ' pop-out '.	21
The pragmatic subject is the object that will become the psychological subject when the structure of its group is attended to, because of its visual features.	21
Objects or groups that are larger or brighter appear nearer and can be pragmatic subjects.	22
The 'appearance' of an object is determined by its pragmatic subject	23
People can search for a target rapidly by looking for objects that have its pragmatic subject	25
Complex objects that do have a structure pop out from simple objects that do not have a structure.	28
Simple objects can 'hide' amongst more complex ones, if they have the same pragmatic subject.	28
Objects that are grouped together can come to share propositional meaning, with experience	32
Functionality is 'what the user does with a system', not 'what the system could do'	32
A coarse texture, like a larger size and increased brightness, makes an object look close	34
In grouping objects, colour and shape ('difference') dominate closeness.	34

Task structures are propositional representations, and can be analysed using structure diagrams and transition path diagrams.	36
An object representation that matches the task structure can help users form the appropriate propositional representation of the task	36
The ambiguity of a transition is a rough guide to the difficulty users will have in making it correctly	38
Transformations from sensory to perceptual levels move up a level in the structure of the information	44
Transformations from central to perceptual levels move down the structure of the information	45
Representations from different sources can blend if their structures are consistent	46
Sound cannot directly produce mental visual images	46
Visual perception can affect the way we interpret sound.	47
Implicational knowledge ensures that propositional blending is 'sensible'.	48
Language is comprehended through propositional blending	48
Qualitative aspects of sound and sight are detected through implicational blending	50
Multimedia interfaces rely on either propositional or implicational blending	51
If propositional representations can be used to group objects as well as to generate a target to search for, search is easier and quicker.	53
Objects that change over time can be perceived as the same object, if the changes can be propositionally blended.	54
Thematic continuity , through collocation of objects that are visually or propositionally related, helps users orient themselves over screen changes.	54